

**ELGI**<sup>TM</sup>

Always Better.

# EN Series Screw Air Compressor

Operation, Maintenance and Parts Manual



CIN:L29120TZ1960PLC000351

**EN 5**  
**400V, 3Ph, 50Hz**





# Product Manual

**EN Series**

**Electric Powered Screw Air Compressor**

**EN 5 - 9.5**

400V, 3Ph, 50Hz

©

**ELGI EQUIPMENTS LIMITED**

Coimbatore, TN - 641 005

Part / Document No. 019000264

**Contact Info:**

**ELGI EQUIPMENTS LIMITED**

Coimbatore, TN - 641 005, India

Tel : 91 - 422 2589555

Fax : 91 - 422 2573697 (Domestic Business)

Fax : 91 - 422 2589401 (International Business)

E-mail : enquiry@elgi.com

Website : www.elgi.com

# Machine Identification and Sale Record



Owner's name / Company name : .....

Phone number : .....

Contact person : .....

E-Mail address/ Phone number : .....

Model : .....

Fab. No. : .....

Year of manufacture : .....

Motor : ..... kW (HP)

Capacity : ..... m<sup>3</sup>/min (cfm)

Rated pressure : ..... bar.g (psi.g)

Date of delivery : .....

Date of commissioning : .....

Dealer name/address : .....

Dealer's signature : .....

**NOTE** *The warranty on the compressor is valid only if all the details above are filled in and the dealer stamps and signs this page. This report must reach the Regional Office/Head Office of ELGi within seven days of commissioning date.*

	<b>Chapter</b>	<b>Page No.</b>
1.0	About ELGi	1.7
2.0	General functional description	2.1
3.0	GA drawing, P&I diagram	3.1
4.0	Specification sheet	4.1
5.0	Installation and operation	5.1
6.0	Maintenance	6.1
7.0	Controller	7.1
8.0	Drive system	8.2
9.0	Cooling system	9.1
10.0	Base and canopy system	10.1
11.0	Airend system	11.1
12.0	Spare kit details	12.1
13.0	Electrical drawings	13.1
14.0	Branch address	14.1

ELGi, established in 1960, designs and manufactures a wide range of air compressors. The company has gained its reputation for design and manufacture of screw compressors through strategic partnerships and continuous research and development. Over the years, it has emerged as a multi-product, multi-market enterprise providing total compressed air solutions to all segments. ELGi's design capabilities translated into a wide range of products ranging from oil-lubricated and oil-free rotary screw compressors, reciprocating compressors and centrifugal compressors.

ELGi is one of the few companies in the world capable of manufacturing wide range of air ends and compressor packages. ELGi has most modern manufacturing facilities with high precision grinding machines, turning centres, CNC horizontal and vertical machining centres and also the latest self measurement technology to maintain precise, aerospace manufacturing tolerances. ELGi's manufacturing plants are ISO and EOHS certified.

Over two million ELGi compressors are powering business in 70+ countries worldwide. The company offers a strong sales and service network with a well-knit distribution network of dealers and distribution, worldwide. ELGi has its own manufacturing operations in India, Italy and USA with subsidiary offices in Australia, Bangladesh, Brazil, China, Indonesia, Italy, Malaysia, Middle East, Sri Lanka and Thailand. The company is fast expanding its global footprint, attracting distributors and customers with its new generation products.

### Need help...?

#### In India

You can contact ELGi customer care system (ECCS) to take care of customer complaints. The ELGi CCS works for six days a week from 08:30 to 21:30 IST (Monday to Saturday). The complaints can be logged by calling any of the following toll free numbers or by e-mail.

**Toll free** : **1800 425 3544**

**E-Mail** : [ccs@elgi.com](mailto:ccs@elgi.com)

**Website** : [www.elgi.com](http://www.elgi.com)

Before making service request for your compressor, keep ready the details printed on the name plate of the compressor and machine identification and sale record of this manual. When ordering spare parts, refer to the lists provided in the parts manual and identify the part number. Specify the part number and quantity, in addition to the name plate details.

Refer "ELGi services" for more details about ECCS under chapter "Maintenance".







<b>Contents</b>	<b>Page No.</b>
<b>2.1 Using the manual</b>	<b>2.2</b>
2.1.1. Definitions and symbols	2.2
<b>2.2 Introduction</b>	<b>2.5</b>
<b>2.3 Safety</b>	<b>2.6</b>
2.3.1 Precautions during installation	2.6
2.3.2 Precautions during operation	2.7
2.3.3 Precautions during maintenance	2.9
<b>2.4 Functional description</b>	<b>2.11</b>
2.4.1 Air circuit	2.11
2.4.2 Oil circuit	2.11
2.4.3 Drive system	2.11
2.4.4 Control system	2.12

## 2.1 Using the manual

This operation and maintenance manual has been specially designed keeping the customer in mind so that the person can get the most out of this EG compressor.



SL-XX-CS04A

Before starting the compressor, it is requested that the manual should be read thoroughly. It contains vital information about installation, commissioning, operation and useful tips on maintenance to keep the compressor as good as new, year after year. The manual has been prepared with utmost care to help you understand the various systems of the compressor, along with descriptions, information and illustrations.

Following chapters are provided to help operate the compressor in its best way.

- **Safety** - safety precautions that must be followed while using the compressor.
- **Technical specifications** - technical details about the compressor.
- **Installation and commissioning** - all site requirements, procedures to be followed during installation, commissioning, preservation etc.
- **Functional description** – parts, their function and working.
- **Operating instructions** – to operate the compressor properly.
- **Maintenance** – how to do the maintenance for the compressor and their intervals.
- **Troubleshooting** – identification and solving the problems.
- **Decommissioning** – how to decommission the compressor, its disposal etc.
- **ELGi services** – services from ELGi: CCS, air audit, spare parts
- **Appendix** – conversion tables, torque values, service log book

Refer to the parts manual to identify the part number of the required spare. Mention the Fab number, model and part number while ordering.

**This manual must be made available to the compressor operating and maintenance personnel at all times.**

### 2.1.1 Definitions and symbols

This information is related to your safety and also to prevent any problems relevant to the equipments used. To help recognize this information better, the symbols are illustrated in section “**safety**”.

All the information, illustrations and specifications in this manual are based on the latest product information at the time of preparation of the manual. Product improvement is a continuous process in ELGi. The details in this manual are likely to change without notice and ELGi reserves the right to incorporate such changes.

#### NOTE

*Note clarifies procedures or conditions which may otherwise be misinterpreted or overlooked. Note may also be used to clarify apparently contradictory or confusing situations.*

#### WARNING





*Warning calls attention to dangerous or hazardous conditions inherent to the operation, cleaning and maintenance of the compressor which may result in fatal accident and personal injury of the operator or other staff*





#### CAUTION

*Caution is to draw attention to a procedure which, if not done correctly can lead to compressor damage.*

# Symbols and Meanings

No	Decal	Description	No	Decal	Description				
SL-XX-CS04A		<p><b>CAUTION</b></p> <p><b>Read Manual</b></p> <p>Read instruction manual before start of operations with the equipment.</p>	SL-XX-DS05A		<p><b>DANGER</b></p> <p><b>Automatic Start-up</b></p> <p>This equipment has automatic start-stop control system.</p> <p><b>Hazardous Voltage</b></p> <p>Improper use of equipment can cause severe injury or death.</p> <p><b>Disconnect Source</b></p> <p>Disconnect equipment from electrical source before performing any maintenance.</p> <p><b>Earth Equipment</b></p> <p>Connect equipment's earth terminal to ground to avoid possible ground fault shock hazard.</p>				
SL-XX-DS01A		<p><b>DANGER</b></p> <p><b>Hazardous Voltage</b></p> <p>Improper use of equipment can cause severe injury or death.</p>			SL-XX-CS06A		<p><b>WARNING</b></p> <p><b>Do Not Remove</b></p> <p>Do not remove caps, plugs or other components when compressor is operational or pressurized.</p> <p><b>Relieve Pressure</b></p> <p>Stop compressor and relieve all internal pressure before removing caps, plugs or other components.</p>		
SL-XX-DS02A		<p><b>DANGER</b></p> <p><b>Crush Hazard</b></p> <p>Moving parts can crush and cut. Keep hands clear</p>					SL-XX-CS12A		<p><b>WARNING</b></p> <p><b>Earth Equipment</b></p> <p>Connect equipment's earth terminal to ground to avoid possible ground fault shock hazard.</p>
SL-XX-DS03A		<p><b>DANGER</b></p> <p><b>Hot Surface</b></p> <p>Contact can cause severe burn injury. Do not touch.</p>							SL-XX-CS02A
SL-XX-DS04A		<p><b>DANGER</b></p> <p><b>Cut Hazard</b></p> <p>Rotating fan blade and parts can cause severe injury. Keep hands and body clear.</p> <p><b>Ensure Fan Guards</b></p> <p>Ensure fan guards are in place before operating the equipment.</p>	SL-XX-CS01A		<p><b>DANGER</b></p> <p><b>Respiratory Hazard</b></p> <p>Hot or noxious gases outlet. Do not use as breathing air.</p>				
SL-XX-DS06A		<p><b>DANGER</b></p> <p><b>Crush Hazard</b></p> <p>Rotating parts can crush and cut. Keep hands clear.</p> <p><b>Ensure Guards</b></p> <p>Ensure guards are in place before operating the equipment.</p>							

No	Decal	Description
SL-XX-CS07A		<p><b>NOTICE</b></p> <p><b>Check Oil Level</b> Check oil level when the equipment is in switch OFF condition.</p> <p><b>Use Correct Oil</b> Use recommended oil and prevent system contamination.</p> <p><b>Read Manual</b> Read instruction manual before start of operations with the equipment</p>
SL-XX-CS03A		<p><b>NOTICE</b></p> <p><b>Read Manual</b> Read instruction manual before start of operations with the equipment.</p>
IL-XX-X008A		<p><b>NOTICE</b></p> <p>Fork lift entry.</p>
IL-XX-X016A		<p><b>NOTICE</b></p> <p>Lifting provision.</p>
IL-XX-X017A		<p><b>NOTICE</b></p> <p>Hand pallet entry.</p>

No	Decal	Description
IL-XX-X005A		<p><b>NOTICE</b></p> <p>Water inlet</p>
IL-XX-X004A		<p><b>NOTICE</b></p> <p>Water outlet</p>
SL-XX-CS16A		<p><b>WARNING</b></p> <p>Elgi Air Lube XD Mineral Oil</p>
SL-XX-CS15A		<p><b>WARNING</b></p> <p>Elgi Air Lube UT Synthetic Oil</p>

Welcome to the ELGi customer family. ELGi compressors are the source of compressed air in various segments across the globe.

ELGi compressors are known for:

- Greatest reliability
- Fewer maintenance intervals
- Ease of use
- Highest safety

The ELGi screw compressor is designed to deliver:

- High energy efficiency
- Low maintenance cost
- High discharge air quality

All the above factors assure a low life-cycle cost.

The rotors incorporate a specially designed eta-v profile-ELGi patented profile-which emphasizes on improving reliability, performance, and efficiency. The Eta-v profile is the latest and the most energy efficient profile in the industry globally, assuring consistent performance during the entire life of the compressor. ELGi screw air compressors incorporate a compact design and compressor run with low noise or vibrations. The capacity control system ensures optimum air intake during start-up, normal running, and unloading stages, minimizing power consumption. The oil separation system ensures that maximum oil is separated from compressed air, ensuring the best air quality with very little oil carry-over.

### Uptime

At ELGi, we are changing the way you look at compressed air systems. It's no longer just about delivering air. It's about delivering uptime. Our uptime design ensures that the compressors run cooler, cleaner, and longer with longer service intervals. The uptime components deliver the best in quality and enable your compressor to run smoothly, efficiently, and profitably. With uptime assurance, we back our pledge, with industry-leading warranties, parts availability, loaner compressors, and call centres staffed by experts. We thank you for purchasing an ELGi compressor and assure you the best service during the entire life of the compressor.

### EN SERIES

Your EN SERIES compressor belongs to a family of rotary screw compressors from ELGI. The compressor has only two moving parts - the rotors - which are separated by a thin film of oil to prevent wear and increase compressor reliability.

The screw compressor technology ensures that output capacity does not diminish even after many years of operation. It involves a continuous flow of air through helical cavities in the screw so that compressed air delivery is pulsation free.

EN SERIES compressors ship in a compact design and are self-contained. The absence of reciprocating parts helps the compressor run without noise or vibration. The discharge temperature of the coolant oil is low, less than 195°F (90°C) under normal conditions, and therefore, carbonized oil does not form in the compressor.

### Salient Features

- Two-stage air filter
- Improved air filter life cycle
- Noise-free package suitable for in-house operations
- High volumetric efficiency
- Efficient air-oil separation by OSBID (Oil Separation By Impact and Deceleration)
- Reliable fan that works even at high temperatures
- Robust cooling system
- Industrial designed canopy
- Compact and hardly space-intensive
- Split-type oil coolers for easy serviceability
- Flush type panels for easy handling
- Anti-vibration mounts for restricted vibration
- Increased life of consumables
- Zero-leak flanged joints.
- Oil carry-over < 3 ppm
- Advanced Neuron controller
- Globally certified product - CE / UL and other country specific approvals.

The operator must follow the safe working practices, instructions, procedures that this manual describes for safe operation. The maintenance personnel must be adequately trained, and have read and thoroughly understood this 'Operation and maintenance manual'. Decals are affixed at specific locations of the compressor and they illustrate very important safety precautions.

### 2.3.1 Precautions during installation

- Ensure that you fasten all loose parts before lifting. Select the appropriate lifting equipment by considering the local safety regulations, size and weight of the compressor. Operate the lifting equipment carefully within the safe operating limits. Ensure all necessary personal protective equipment's (PPEs) is close at hand during this operation.
- Maintain a cool and clean ambient for the compressor



and ensure that the air inlet is not obstructed. Make arrangements to reduce the moisture entry through the incoming air.

- Remove protection such as caps, plugs, desiccant bags before connecting the air line pipes.
- Remove the red colored protective clamps from the airend and motor while commissioning the compressor.



SL-XX-CS04A

- Do not use frayed, damaged or worn hoses. Distribution pipes and connections must be of the correct size and suitable for working pressure.
- Make sure that the aspirated air by the compressor is free of flammable fumes, vapors and particles, to prevent internal fire or explosion.
- For remotely controlled compressors and auto-start compressors, provide a clear caution stating:



SL-XX-D002A

**“DANGER” – Remotely controlled machine and will start without notice**

- Ensure the operator is located far away from the intake of the compressor.
- Position the after-cooler discharge pipe in a way that it is free to expand under heat and is not in contact with or close to flammable materials.
- Do not exert external force on the air outlet valve and keep the connected pipe always free of strain.
- Make available adequate cooling air must be made available for the compressor particularly air cooled compressors. Make sure that exhausted air does not circulate back to the intake or cooling system.
- Make the electrical connections according to the legal standards and earth the compressor suitably. Provide a sufficient number of fuses and other protective devices to protect the compressor against short circuits. Good practice is to provide an isolating switch nearby the compressor.
- Install manual valves behind non-return valves (NRV) to isolate each compressor in multi-compressor systems. Do not rely on NRV for isolating pressure systems.
- Do not bypass, remove or adjust the safety devices or other attachments residing on the compressor. Every installed pressure vessel or auxiliary outside the compressor should have pressure relieving device or devices, as required.



SL-XX-DS05A



SL-XX-CS01A

- Danger! Be aware that compressed air used for breathing or food processing must meet O.S.H.A. 1910.134 or F.D.A. 21 C.F.R. 178.3570 regulations. Failure to do so may cause severe injury or death.
- Insulate or use protective guards to cover pipes or other parts that may exceed 80°C (176°F). High-temperature pipes must have a clear marking as potentially dangerous.
- Position the compressor on level surface. In case of inclined surface, contact ELGi.
- Do not allow compressed air to come in contact with food and related items unless they are compressed air-treated specifically.
- Be aware that this air compressor is intended for
- generating only industrial-use compressed air.

### 2.3.2 Precautions during operations

- When switching on remotely controlled compressors ensure that no one is checking or working on the compressor at that time.
- Before starting, ensure that no tools or any loose parts remain inside the compressor.
- Do not operate the compressor if a possibility exists that it could inhale flammable or toxic fumes, vapors or particles.
- Do not operate the compressor below or above its operating limits.
- Wear ear protectors if you work in an environment where the sound pressure level reaches or exceeds 90 dB (A).
- Keep all the compressor doors shut during operation. For carrying out routine checks, the doors should open only for short durations not more than 10 minutes. Wear ear protectors when opening a door.
- Keep hands, feet, floors, controls and walking surfaces clean and free of water or other liquid to minimize the possibility of slips and falls.

#### Pressure release

- Know that annual servicing of the safety valve is necessary. It should be checked at the prescribed pressure for operation.
- Use correct tools for maintenance and repair work. Do not allow the manufacturers' rated safe operating pressure to exceed for pipes, valves, filters and other fittings.
- It is hazardous to point the compressed air directly towards any personnel. Keep personnel out of the line of the discharge air when opening hoses or other points of compressed air discharge.
- Use only the correct type and size of hose end fittings and connections. When blowing through a hose or airline ensure that the open end stays securely. A free end will whip and may cause injury. Make sure to depressurize a hose fully before disconnecting it.

- Release all the pressure in the compressor system before servicing or performing any maintenance activity.
- Do not engage in horseplay with air hoses. Serious injury or death may result.
- Do not use air at a pressure greater than 2.5 bar.g (36 psi.g) for cleaning purpose.
- Open the oil fill cap only when the compressor is not running and is not pressurized. Shut down the compressor and bleed the receiver tank to zero internal pressure before removing the cap.

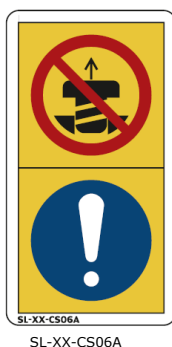

#### Fire and explosion

- Clean up spills of lubricants or other combustible

substances immediately.

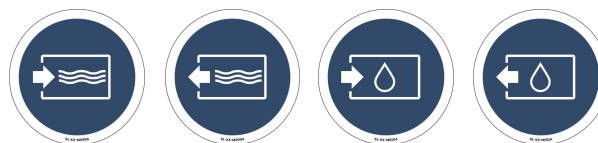

- Shut down the compressor and allow it to cool down before checking or adding oil. Remove sparks, flames and other sources of ignition away from the compressor.
- Do not permit smoking in the vicinity of the compressor.
- Do not use flammable solvents for cleaning purposes.
- Keep electrical wiring and other terminals in good condition. Replace any wiring that has cracked, cut, abraded or otherwise degraded insulation. Keep all terminals clean and tight.
- Keep grounded conductive objects such as tools away from exposed live electrical parts like terminals to avoid arcing, which might serve as a source.
- Keep oily rags, trash, dry leaves, litter or other



combustibles out of and away from the compressor.

- Do not operate the compressor without a proper flow of cooling air or with an inadequate flow of lubricant or with a degraded lubricant.

Do not attempt to operate the compressor in a hazardous environment of any classification unless the compressor has been specially designed and manufactured for explosive applications.

#### Moving Parts

- Rotating fan blades can cause serious injury. Disconnect power supply before attempting service.
- Keep compressor doors closed except when servicing or during maintenance. The sound damping material on the inner side of the compressor body should not be removed or tampered with.



- Wear snug-fitting clothing and tie long hair when working around the compressor, especially when hot or moving parts such as the cooler, the airend, the thermal valve, the main motor or the fan motor are exposed.

- Keep hands, arms and clothing away from couplings, fans/belts and other moving parts.
- Do not attempt to operate the compressor with the fan guards, coupling guards/belt guards or other guards removed.
- Keep hands, feet, floor, controls and walking surfaces clean and free of fluid, water or other liquids to minimize the possibility of slips and falls.

**Hot surfaces**



SL-XX-DS03A

- Avoid bodily contact with hot oil and hot surfaces like cooler, pipes etc.
- Keep all parts of the body away from all points of air discharge.
- Keep a first aid kit handy. Seek medical assistance promptly in case of injury. Do not ignore small cuts and burns.

**Toxic and irritating substances**

- Do not use air from the compressor for breathing.
- Always wear safety equipment while operating the compressor. Refer OSHA safety standards.



SL-XX-CS01A

- Do not allow compressed air to come into contact with any edible items.
- In the event of ingestion of oils, coolants or lubricants used in the compressor, seek medical treatment promptly. In case you come in contact with such substances, wash with soap and water. Use MSDS for oil to know more on this.
- If warm cooling air from the compressor is being used in air heating systems, e.g. to warm up a work room, take precautions against air pollution and possible contamination of the breathing air.

**Electric shock**

- Keep all parts of the body and any handheld tools or other conductive objects away from exposed live parts of the electrical system.
- Stand on a dry or insulating surface and do not contact

any other part of the compressor when making adjustments or repairs to exposed live parts of the electrical system.

- Before switching on the compressor ensure that proper earthing is done as per recommendation.



SL-XX-DS01A

- Make all adjustments or repairs with one hand. This minimizes the risk of creating a current path through the heart.
- Conduct repairs only in a clean, dry, well-lit and ventilated area.
- Do not leave the compressor unattended with open electrical enclosures. If necessary to do so, disconnect the power to the compressor at the source and lock it out so that power is not inadvertently restored.
- Disconnect, lock out, and tag the power source prior to attempting repairs or adjustments, turning the

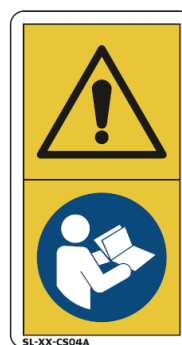

SL-XX-CS04A



SL-XX-M007B

- compressor manually or handling ungrounded conductors.
- All electrical installation must be in accordance with recognized electrical codes and any local health & safety codes.
- Recognize that only authorized and qualified trained personnel should carry out any electrical work on the compressor.
- Regularly check that all electrical connections are tight and in good condition.

**Periodically check whether**

- All guards are in place and securely fastened.
- All hoses and pipes inside the compressor are in good condition, secure and not rubbing against each other.
- Any leaks exists.



- All fasteners are tight.
- All electrical leads are secure and in good order.
- Safety valves and other pressure relief devices are not obstructed by dirt or paint.
- Air outlet valve, i.e. pipes, couplings, manifolds, valves, hoses, etc. are in good repair, free of wear or abuse.
- The air-oil tank is properly grounded.

### **2.3.3 Precautions during maintenance**

- Use safety glasses and incorporate safe working practices before maintenance work.
- Use appropriate tools for all maintenance works.
- Use only genuine spare parts. Refer the **section "Use genuine spare parts"** in **"Maintenance"** chapter.
- Ensure that the compressor is cooled down before maintenance is performed.
- Springs under tension or compression store energy. Uncontrolled release of this energy can cause serious injury or death. Be cautious while performing the maintenance of components loaded with springs (for example minimum pressure valve, safety valve etc.).
- Display a warning sign that says **"Maintenance under progress, don't switch on"** near the start switch.
- Isolate the compressor from the air line (discharge) and disconnect the power by opening and locking the isolating switch before maintenance.
- Prior to attempting repairs or adjustments, disconnect the power at the source and verify at the compressor that the circuits have de-energized. This minimizes the possibility of accidental start-up or operation, especially when the compressor is remotely controlled.
- Open the oil filler cap only when the compressor is not running and is not pressurized. Shut down the compressor and bleed the receiver tank to zero internal pressure before removing the cap.
- If you are going to switch on remotely controlled compressors must ensure that nobody is checking or working on the compressor at that time. A warning sign near the equipment's start button is mandatory.
- Wait up to five minutes to ensure that the air in the air-oil separator tank is released to start routing maintenance.
- Vent all internal pressure prior to opening any line, fitting, valve, drain plug, connection or other components such as filters. Vent pressure by popping up the safety valve.
- Display a maintenance chart near the compressor to easily identify the maintenance intervals of regular service items.



## 2.4 Functional description

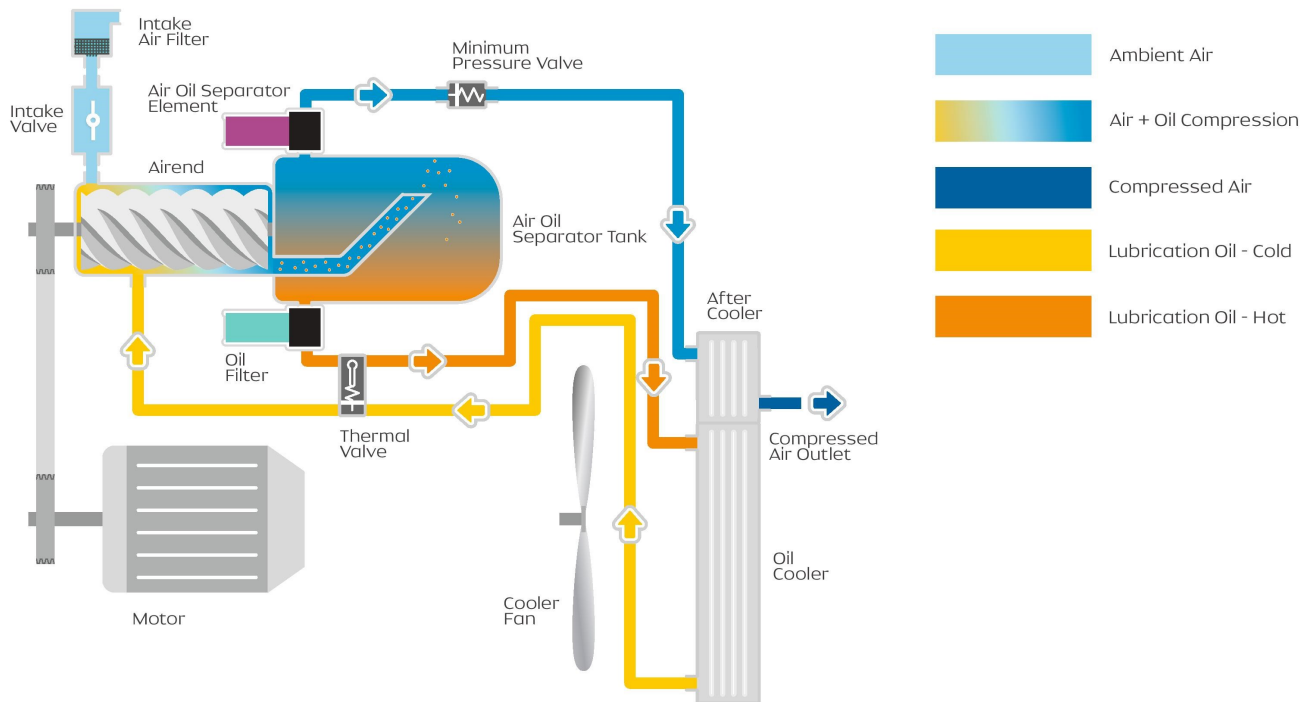

Figure 1. Screw compressor systems - Schematic diagram

### 2.4.1 Air circuit

Atmospheric air enters into the airend through the air intake system. The intake filters (pre filter and air filter) prevent the entry of foreign particles (such as dust) into the airend. Dust and micro particles above 10 microns are separated by the pre filter and particles above 3 microns are filtered off by the air filter. The intake valve regulates the amount of air sucked into the airend. The opening and closing of the intake valve is controlled by the pneumatic pulse line actuated by the electrically controlled solenoid valve.

The filtered air enters into the airend where it mixes with the injected oil. The injected oil acts as a coolant to maintain optimum temperature. It also seals the leaks between the rotors and the housing and lubricates the bearings and gears. The airend consists of two counter-rotating intermeshed helical screws — the male and female rotors — which are driven by an electric motor. The air-oil mixture is trapped between the rotors of the airend and is progressively compressed.

After being compressed, the air-oil mixture enters into the air-oil separator tank, with high velocity, where it undergoes a unique 3-stage separation process to remove maximum oil content. This highly efficient 3-stage separation process uses the impact velocity of the air-oil mixture along with the OSBID process to make the mixture very lean. The final stage of this separation consists of passing the lean mixture through the air-oil separator element to ensure an oil content of 3 ppm and less in the air.

The oil separated and collected in this element is then returned to the airend through the scavenging line. The air passes through a minimum pressure valve (MPV). It maintains a minimum differential pressure required for circulation of oil within the compressor unit. The compressed hot air is cooled in the after-cooler. .

### 2.4.2 Oil circuit

The separated oil in the air-oil separation tank flows into the airend. The oil either diverts to the oil cooler or oil filter or both depending upon the temperature. The thermal valve governs and controls the oil flow path. The oil before being injected into the airend is filtered. An orifice residing in the oil flow path towards the airend controls oil flow. Any small quantity of oil, separated and stored in the separator element, enters into the airend through the scavenging line. The whole oil circulation circuit in the compressor is operated solely by the differential pressure maintained by the minimum pressure valve (MPV) and doesn't require any additional pump.

### 2.4.3 Drive system

The airend is powered by an electric induction motor through a belt and pulley. When the compressor is turned ON, the motor is started in star mode and it takes 6 to 9 seconds to change over to delta mode. During this period, the intake valve closes and thus the motor starts without load. In delta mode, the motor speed stabilizes, the solenoid valve energizes after 10 seconds of changeover to reduce motor load, the blow down valve closes, the intake valve opens and the compressor starts loading. This ensures very little starting load. Next, the intake valve opens and the system starts building up pressure. Anti-vibration mountings reside below the airend and the motor. This configuration reduces the transmission of vibration from both the airend and motor to the structure, reducing noise and ensuring reliability of the parts mounted on the structure.

#### 2.4.4 Control system

Depending on the demand for compressed air from the application at a particular time, the compressor needs to respond accordingly. The compressor, therefore, operates in either loading or unloading mode to meet this requirement. The primary objective of these modes is to save energy and reduce wear and tear on the machine. The control system ensures a smooth start without overloading the motor.

The compressor is started in star mode, during which most of the compressed air is vented to the atmosphere. This mechanism helps prevent overloading of the motor. In delta mode, the motor speed stabilizes, the solenoid valve energizes after 10 seconds of change-over to reduce load on the motor, the blow-down valve closes, and the compressor starts loading.

When the receiver pressure reaches the maximum limit, a signal arrives at the solenoid valve from the control system. Next, the inlet valve actuates and closes, and the compressor runs in unloading mode. If unloading mode continues for more than 5 minutes, i.e., no compressed air is consumed and thus no decrease in pressure occurs, the system stops and switches to standby mode. If a drop in pressure occurs in the receiver, the compressor returns to loading mode automatically.





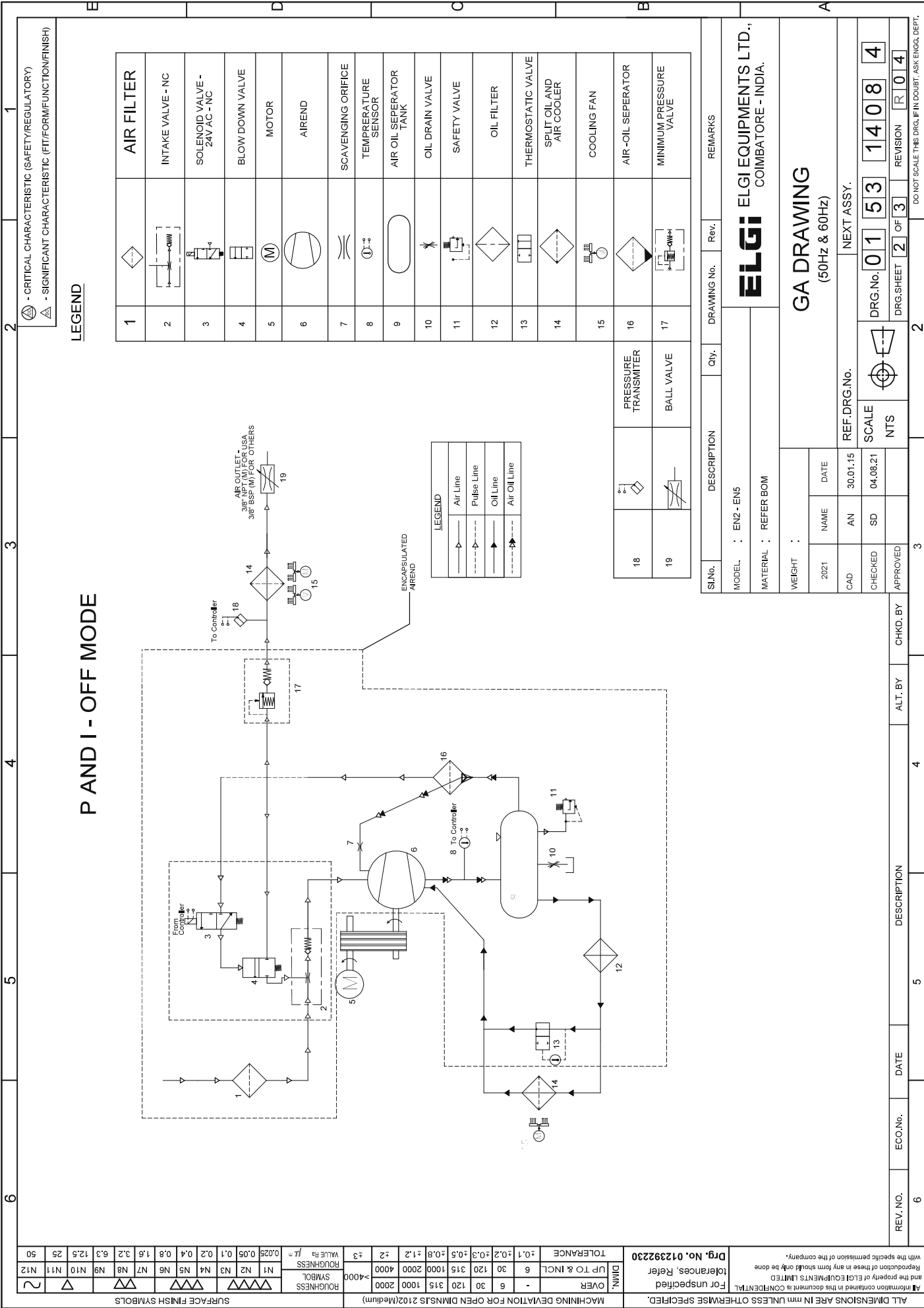

# P AND I - OFF MODE

## LEGEND

1		AIR FILTER
2		INTAKE VALVE - NC
3		SOLENOID VALVE - 24V AC - NC
4		BLOW DOWN VALVE
5		MOTOR
6		AIREND
7		SCAVENGING ORIFICE
8		TEMPERATURE SENSOR
9		AIR OIL SEPARATOR TANK
10		OIL DRAIN VALVE
11		SAFETY VALVE
12		OIL FILTER
13		THERMOSTATIC VALVE
14		SPLIT OIL AND AIR COOLER
15		COOLING FAN
16		AIR -OIL SEPARATOR
17		MINIMUM PRESSURE VALVE
18		PRESSURE TRANSMITTER
19		BALL VALVE

LEGEND	
	Air Line
	Pulse Line
	Oil Line
	Air Oil Line

SI.No.	DESCRIPTION	QTY.	DRAWING No.	Rev.	REMARKS
18	PRESSURE TRANSMITTER				
19	BALL VALVE				

MODEL : EN2 - ENS  
MATERIAL : REFER BOM

WGT :  
2021 NAME DATE  
CAD AN 30.01.15 REF.DRG.No. NEXT ASSY.  
CHECKED SD 04.08.21 SCALE 1:1  
APPROVED NTS

DRG.No. 015314084  
DRG.SHEET 2 OF 3 REVISION R04

GA DRAWING (50Hz & 60Hz)  
ELGI ELGI EQUIPMENTS LTD., COIMBATORE - INDIA.

MACHINING DEVIATION FOR OPEN DIMS (S 210Z (Medium))		±3	±2	±1.2	±0.8	±0.5	±0.3	±0.2	±0.1
SURFACE FINISH SYMBOLS		ROUGHNESS SYMBOL	ROUGHNESS VALUE Ra μm	0.025	0.05	0.1	0.2	0.4	0.8
2	Δ	N1	4-000	0.025	0.05	0.1	0.2	0.4	0.8
50	Δ	N12		12.5	12.5	12.5	12.5	12.5	12.5

ALL DIMENSIONS ARE IN mm UNLESS OTHERWISE SPECIFIED.  
For unspecified tolerances, Refer UP TO & INCL 6 ±0.1  
OVER 6 ±0.2  
30 ±0.3  
120 ±0.3  
315 ±0.5  
1000 ±0.8  
2000 ±1.2  
4000 ±2  
8000 ±3

Drng. No. 012392230

Information contained in this document is CONFIDENTIAL and the property of ELGI EQUIPMENTS LIMITED. Reproduction of these in any form should only be done with the specific permission of the company.

REV. NO.	ECO.No.	DATE	DESCRIPTION	CHKD. BY	ALT. BY
6					

DO NOT SCALE THIS DRG. IF IN DOUBT, ASK ENGR. DEPT.

6 5 4 3 2 1

MACHINING DEVIATION FOR OPEN DIMENSIONS (2102/Medium)		SURFACE FINISH SYMBOLS	
ROUGHNESS SYMBOL	ROUGHNESS VALUE Ra $\mu m$	ROUGHNESS SYMBOL	ROUGHNESS VALUE Ra $\mu m$
N1	0.025	N1	0.05
N2	0.05	N2	0.1
N3	0.1	N3	0.2
N4	0.2	N4	0.4
N5	0.4	N5	0.8
N6	0.8	N6	1.6
N7	1.6	N7	3.2
N8	3.2	N8	6.3
N9	6.3	N9	12.5
N10	12.5	N10	25
N11	25	N11	50
N12	50	N12	

TOLERANCE		DIM./INCL.	
±0.1	±0.2	6	30
±0.2	±0.3	120	120
±0.3	±0.5	315	1000
±0.5	±0.8	120	315
±0.8	±1.2	1000	2000
±1.2	±2	4000	4000
±3	±4000		

REV. NO.	ECO.No.	DATE	DESCRIPTION	ALT. BY	CHKD. BY
6					
3					
2					

SI.No.	DESCRIPTION	Qty.	DRAWING No.	Rev.	REMARKS
	MODEL : EN2-ENS				
	MATERIAL : REFER BOM				

<b>ELGI</b> ELGI EQUIPMENTS LTD., COIMBATORE - INDIA.	
<b>GA DRAWING</b> (50Hz & 60Hz)	
DRG.No.	015314084
DRG.SHEET	3 OF 3
REVISION	R04

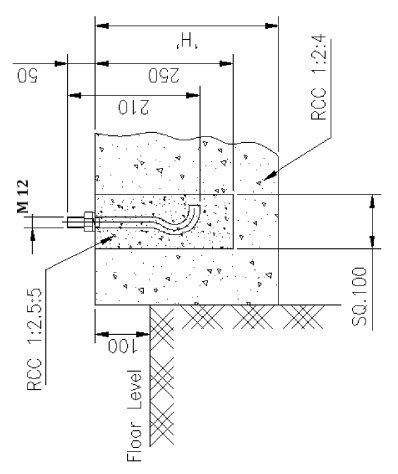
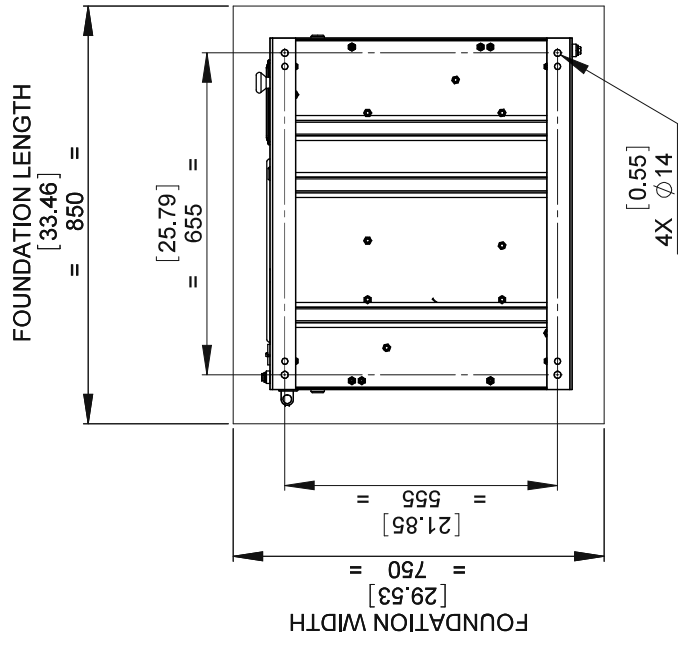

The dimension 'H' shall be determined by the Customer according to the ground condition.

(OPTIONAL)

PACKAGE WEIGHT DETAILS				
MODEL	EN2	EN3	EN4	EN5
INDIA (in Kg)	133	133	143	150
EUROPE AUSTRALIA MIDDLE EAST SAUDI (in.kg)	143	143	143	150
USA (in lbs)	352	352	352	402

WEIGHT : 2021 NAME DATE AN 30.01.15 SD 04.08.21 APPROVED NTS		REF.DRG.No. SCALE NTS	NEXT ASSY. DRG.No. 015314084 DRG.SHEET 3 OF 3 REVISION R04
--	--	-----------------------------	---

ALL DIMENSIONS ARE IN mm UNLESS OTHERWISE SPECIFIED.

Do NOT SCALE THIS DRG. IF IN DOUBT, ASK ENGR. DEPT.

## 4.0 Technical data

### Standard

Model	-	EN 2				EN 3					
		7.0	8.0	9.5	10.0	7.0	8.0	9.5	10.0	12.5	
Working pressure	bar.g	7.0	8.0	9.5	10.0	7.0	8.0	9.5	10.0	12.5	
FAD - Free air delivery	cfm	13.1	13.0	9.0	9.0	16.9	16.6	13.1	13.0	9.7	
	m <sup>3</sup> /	0.37	0.37	0.26	0.25	0.48	0.47	0.37	0.37	0.27	
Unloading pressure	bar.g	7.2	8.2	9.7	10.2	7.2	8.2	9.7	10.2	12.7	
Nominal power supply	-	400V(+/-10%),50Hz(+/-5%),3Phase									
Main motor rating	kW	3.7									
Type of motors (main drive & fan drive)	-	3Ph squirrel cage induction motor and 1Ph fan motor									
Insulation and protection of main motor	-	Class F / IP 55									
Frame size / mounting type	-	112M/B3									
Type of starter for main motor	-	Direct online starter									
Maximum fan motor rating per fan X no. of fans	kW	0.063 x 1									
Rated speed of fan motor	rpm	2850									
Safety valve set pressure	bar.g	15									

### Standard

Model	-	EN 4					EN 5				
		7.0	8.0	9.5	10.0	12.5	7.0	8.0	9.5	10.0	12.5
Working pressure	bar.g	7.0	8.0	9.5	10.0	12.5	7.0	8.0	9.5	10.0	12.5
FAD - Free air delivery	cfm	19.2	18.0	15.4	16.5	14.2	26.1	26.0	23.0	23.0	18.6
	m <sup>3</sup> /	0.54	0.51	0.44	0.47	0.40	0.74	0.74	0.65	0.65	0.53
Unloading pressure	bar.g	7.2	8.2	9.7	10.2	12.7	7.2	8.2	9.7	10.2	12.7
Nominal power supply	-	400V(+/-10%),50Hz(+/-5%),3Phase									
Main motor rating	kW	3.7					5.5				
Type of motors (main drive & fan drive)	-	3Ph squirrel cage induction motor and 1Ph fan motor									
Insulation and protection of main motor	-	Class F / IP 55									
Frame size / mounting type	-	112M/B3					132S/B3				
Type of starter for main motor	-	Direct online starter					Star delta starter				
Maximum fan motor rating per fan X no. of fans	kW	0.063 x 1									
Rated speed of fan motor	rpm	2850									
Safety valve set pressure	bar.g	15									



<b>Contents</b>	<b>Page No.</b>
<b>5.1. Installation and commissioning</b>	<b>5.2</b>
5.1.1 Commissioning procedure	5.2
5.1.2 Unpacking	5.2
5.1.3 Handling the compressor	5.2
5.1.4 Site requirements	5.3
5.1.5 Ventilation and exhausting hot air	5.4
5.1.6 Electricals	5.4
5.1.7 Air pipe line	5.5
5.1.8 Oil filling procedure	5.7
5.1.9 Procedure for changing oil the compressor during service	5.7
5.1.10 Direction of rotation	5.8
<b>5.2. Preservation for long idle storage</b>	<b>5.9</b>
5.2.1 Airend	5.9
5.2.2 Motor	5.9
5.2.3 Air-oil separator tank	5.9
5.2.4 Disposal of Packing	5.9
<b>5.3. Operating instructions</b>	<b>5.10</b>
5.3.1 Safety system and interlocking Device	5.10
5.3.1.1 Discharge temperature sensor	5.10
5.3.1.2 Minimum pressure valve	5.10
5.3.1.3 Pressure relief valve	5.10
5.3.1.4 Overload relays for main motor and fan motor	5.10
5.3.2 Operation control system	5.10
5.3.3 starting the equipment	5.10
5.3.4 starting and normal operation mode	5.10
5.3.5 Unloading mode	5.10
5.3.6 Stopping	5.10

### 5.1.1 Commissioning

Before you operate the new EN series compressor for the first time, install it at your site according to ELGI's Installation specifications.

For safe operation of the compressor, the servicing technician performs a series of checks on the compressor and the systems to which the compressor connects. The technician will explain to the compressor operator how to operate and maintain the equipment. This procedure is referred to as the commissioning process.

The commissioning of your compressor is a necessary safety step. The general operating conditions of the equipment, including the cleanliness of the ambient atmosphere, the temperature and ventilation, are checked. Technical details relating to your system, such as particulars of your electrical installation, are verified. The commissioning process includes familiarizing your compressor operator with all aspects of the compressor's normal running and dealing with unusual situations.

Please make preparations according to the instructions provided in the Installation section for your EN Series compressor to be commissioned. Ensure that the location chosen meets the requirements of accessibility, ventilation, and safety. Provide electrical power as recommended in the Installation section. Select air pipe lines and receivers for your system according to the tables provided in the same section.

After completing the commissioning process, the technician will fill in the commissioning report and the warranty card.

### 5.1.2 Unpacking

Unpack the compressor from the packing case by removing the nails or pins. Unscrew the bolts as you hold

#### NOTE

*Ensure belt tension as per the drive table during commissioning.*

the compressor to the base of the crate.

Once you have separated the packing material, check the contents against the packing list. The compressor ships with the following items:

- The key to doors
- The operation and maintenance manual
- A checklist of parts of the machine
- An electrical drawing

Tools may be provided on request. If any components are missing, contact ELGI immediately.

### 5.1.3 Handling

- If the compressor consists of a lifting bail, then use only the bail to lift the bail machine. If no bails exist, lift the bail machine using slings. Always use slings and not the lifting bail to airlift compressors by helicopter.
- Prior to lifting, inspect the lifting bails and points of attachment for cracked welds; for cracked, bent,

corroded or otherwise degraded members; and for loose bolts and nuts.

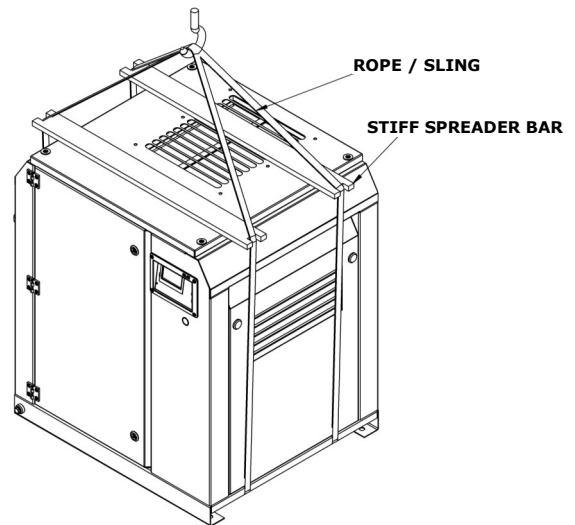

Figure 2. Lifting using crane

- Make sure the entire lifting, rigging, and supporting structure has been inspected, is in good condition, and has a rated capacity of at least the net weight of the compressor. If you are unsure of the weight, then weigh the compressor before lifting it.
- Make sure the lifting hook has a functional safety latch, or equivalent, and is fully engaged and latched on the bail.
- Use guide ropes or equivalent to prevent twisting or swinging of the machine once it has been lifted clear off the ground.
- Do not attempt to lift the compressor in high winds.
- Keep all personnel away from the compressor when it is suspended.
- Do not lift the compressor higher than necessary.
- Make sure the lift operator is present throughout the duration that the compressor is suspended.
- Set the compressor down only on a level surface that is capable of supporting at least its net weight plus an additional 10 per cent allowance .

### 5.1.4 Site requirements

- Install the air compressor in a clean, dry, cool, and dust free room as extreme temperatures (hot or cold), moisture, and airborne contaminants can significantly affect compressor performance, durability, and compressed air quality.

#### NOTE

##### Removal of transit brackets:

*Once the compressor settles down in its final position, remove the red painted transit bushes and store for future use.*

##### Locations:

- *Bushes in between the base and structure*

- Be aware the entrance to the compressor room should be high enough and wide enough to carry the compressor in and out.
- Leave a minimum of 1m (3.28ft) space around the compressor for safe and proper inspection, cleaning, and maintenance activities.
- Leave a minimum of 2m (6.56ft) space above the compressor for hot air to flow away from the compressor.
- Ensure the compressor is protected against direct sunlight and rain.
- Avoid exposing the compressor to excessive moisture (from rain, dryer vent, etc.) as moisture can affect

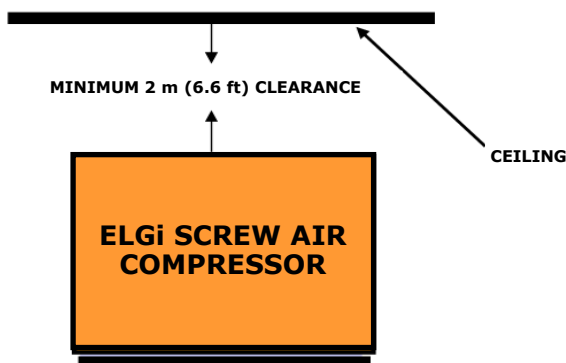

**Figure 3. Vertical clearance around the compressor**

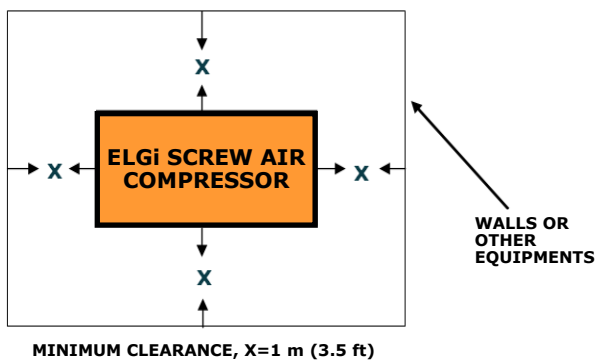

**Figure 4. Horizontal clearance around the compressor**

air and lubrication, promote rust formation on the compressor, and lead to electrical problems of the motor.

- Neither install the machine in a location where flame is used nor place any inflammable objects near the compressor.
- Ensure the room temperature is within 45°C (113°F), as high ambient temperatures will result in reduced oil life due to higher discharge oil temperature (DOT). It also results in high approach temperatures affecting the cooling and condensation efficiency in the after-cooler and in air treatment equipment like air dryers.
- Ensure the hot medium of other utility equipment like gensets/dryers/ boilers, etc., is not sucked by the

compressor inlet or that in any way the room temperature does not rise to prevent high discharge oil temperature.

- Ensure the ambient temperature does not drop below 0°C (32°F). Provide air supply openings and adjustable louvers to ensure that the minimum temperature does not drop down below 0°C (32°F).
- Install the compressor on a smooth, solid, level surface capable of bearing the weight of the compressor. Ensure unevenness of the surface is within 6mm (0.25") and taper is within 50 per meter.
- If the floor is splashed frequently with water while cleaning, then place your compressor on a raised concrete 100 to 150 mm (4 to 6 inches) high.
- If installed on a metallic floor or frame, the frame should be electrically grounded separately.
- Ensure the compressor base makes 100% contact directly with the floor.
- Know that an industrial floor with a level surface capable of supporting the weight of the compressor is sufficient for installing your compressor. No special foundation or anchoring is necessary for rotary screw compressors.
- Do not store toxic, volatile, or corrosive agents near the compressor.
- Isolate the compressor from corrosive agents like ammonia, chlorine, salt spray, and other chemicals as these may erode the internal components and also contaminate the oil and filters.
- Do not allow hot air from additional equipment to blow towards the compressor.
- If you operate in high dust applications like rice mills, cement, flour mills, etc., clean and replace the filters more often.
- Good practice is to have overhead lifting in the compressor room to facilitate any major overhaul. If an overhead hoist is not available, you should be able to use a mobile crane or forklift truck in your compressor room at a minimum.

### 5.1.5 Ventilation and exhausting hot air

- Ensure adequate ventilation in the compressor installation area. Your compressor has a ventilating air requirement of 600 to 1200 cfm.

#### Guidelines to compressor ventilation setup:

Follow these guidelines when providing ventilation for the compressor:

- Provide openings close to the floor level on walls/partitions close to the air suction side of the compressor
- Provide exhaust openings close to the ceiling for hot air exit.
- Ensure the air velocity in the supply and exhaust ducts does not exceed 13.1ft/s (4m/s).
- Determine air velocity during commissioning using an anemometer.
- Do not connect cool air inlet ducts directly to the

compressor inlet side.

- To eliminate transmission of vibrations, provide a soft bellows connector between the duct and the compressor.
- Contact ELGi in case you need to provide a duct connection or filter fitment on the compressor.
- Do not direct forced flow of cool air towards the compressor.
- Locate the compressor such that hot air from other machines is not directed towards it.

### 5.1.6 Electricals Electricals 60Hz

You must provide a lockable main switch unit with pre-connected slow-blow main fuses as per industrial safety regulations. Power supply should be 208/230V 1 Ph 60Hz with earth PE or 208-230V/460V 3 Ph 60Hz with earth PE.

The fuse and cable specifications for 208-230V, 60 Hz 1 Ph, 208-230V 60Hz 3ph and 460V 60Hz 3ph power supplies appear in the table below.

You must also provide a switching fuse unit with pre-connected slow-blow main fuses as per industrial safety regulations. Power supply should be 208/30V 1 Ph with earth PE or 208-230V/460V 3 Ph with earth PE.

The fuse and cable specifications for 208-230V, 60 Hz 3 Ph and 460V 60Hz 3ph power supplies appear in the table below.

### Electricals 50Hz



#### NOTE

Suspended particulate matter should be less than 150 spm to achieve the specified consumable life.

Guarantee is void if the compressor is operated above its intended pressure.

#### WARNING

Ensure that only authorized electricians perform electrical work. Study the electrical circuit diagram before starting work.

#### NOTE

Supply power to the compressor through a fuse switch unit of a suitable rating mounted on the compressor at a height of 5mm.

You must provide a switching fuse unit with pre-connected slow-blow main fuses as per industrial safety regulations. The power supply should be 380V/400V/415V, 50Hz, 3

Power supply	208-230 V 1Ph		208-230 V 3Ph		460 V 3Ph		380 V 3Ph	
Motor Power kW/hp	3.7/5.5	5.5/7.5	3.7/5.5	5.5/7.5	3.7/5.5	5.5/7.5	3.7/5.5	5.5/7.5
Nominal current (A)	25	38	16	24	8	11	9	12.5
Cable material	Copper conductor only							
Power supply cable (AWG) (L=30ft)	3 x 10	3 x 8	4 x 12	4 x 10	4 x 14	4 x 14	4 x 2.5	4 x 4
Upstream fuses (A) (Type RK/CC/J)	32	50	20	32	16	16	16	16
Switching fuse unit (A)	32	63	32	32	20	20	20	20

Power supply	208-230 V 3Ph		208-230 V 3Ph		460 V 3Ph		380 V 3 Ph		
Motor Power kW/hp	7.5/10	11/15	15/20	7.5/10	11/15	15/20	7.5/10	11/15	15/20
Nominal current (A)	32	47	63	15	23	29	17	24	34
Cable material	Copper conductor only								
Power supply cable (AWG) (L=30ft)	3 x 8	3 x 8	3 x 6	3 x 12	3 x 12	3 x 10	4 x 4	4 x 6	4 x 10
Upstream fuses (A) (Type RK/CC/J)	40	63	80	20	32	40	25	32	50
Switching fuse unit (A)	63	63	100	32	32	63	32	32	63

phase with (PE) earthing.

The fuse and cable specifications for 380V/400V/415V, 50Hz, 3 Ph power supplies appear in the table below.

You must provide a switching fuse unit with pre-connected slow-blow main fuses as per industrial safety regulations. The power supply should be 380V/400V/415V, 3 phase with Neutral.

The fuse and cable specifications for 380V/400V or 415V, 50Hz, 3 Ph power supplies appear in the table below .

### Earthing

Verify the total power supply requirements provided on the compressor nameplate before connecting the compressor to electrical lines. Connect the earthing line to the point provided in the control panel box of the compressor.

Model	Recommended pre-connected fuse rating (A)	Incoming copper cable size (mm <sup>2</sup> )/in <sup>2</sup>	Incoming aluminium cable size (mm <sup>2</sup> )/in <sup>2</sup>
2.2 kW	10	2.5/0.1	4/0.15
3 kW	10	2.5/0.1	4/0.15
4 kW	16	2.5/0.1	4/0.15
5.5 kW	16	2.5/0.1	4/0.15
5.5 kW	20	2.5/0.1	4/0.15

7.5 kW	25	4/0.15	6/0.25
11 kW	32	6/0.25	10/0.4
15 kW	50	10/0.4	16/0.6

Check the direction of rotation as per the arrow indication, to check-start the compressor. Stop it immediately after the check-start by pressing the emergency stop button.

Switch on the compressor after ensuring all the above points and let it run at the rated speed.

In case of problems during the compressor operation, check the warning fault code that appears in the controller of the compressor. Refer to the Functional Description and Operation sections of this manual to know more about the fault.



If you hear any abnormal noise when operating the compressor, switch it off immediately and contact the ELGI service engineer.

Follow all above points when you need to reinstall the compressor at a different location. If the compressor had been in storage for an extended period before commissioning, contact the ELGI service engineer.

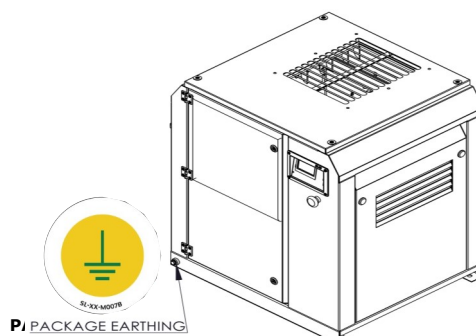

Figure 5. Earthing line of compressor

### 5.1.7 Air pipe dimensions

Volume Flow FAD		NPS Pipe size/ Inside diameter (mm)									
		1/2		3/4		1		1 1/4		1 1/2	
(m <sup>3</sup> /min)	(cfm)	15.80		20.93		26.65		35.05		40.89	
		(bar)	(psi)	(bar)	(psi)	(bar)	(psi)	(bar)	(psi)	(bar)	(psi)
0.1	4	0.02	0.22								
0.2	7	0.06	0.80	0.01	0.20						
0.3	11	0.12	1.69	0.03	0.41	0.01	0.12				
0.4	14	0.20	2.88	0.05	0.71	0.01	0.21				
0.5	18	0.30	4.35	0.07	1.07	0.01	0.32	0.01	0.08		
0.6	21	0.43	6.09	0.10	1.49	0.03	0.45	0.01	0.11		
0.7	25	0.57	8.10	0.14	1.99	0.04	0.59	0.01	0.15		
0.8	28	0.73	10.38	0.18	2.54	0.05	0.76	0.01	0.19	0.01	0.09
0.9	32	0.90	12.90	0.22	3.16	0.07	0.95	0.02	0.24	0.01	0.11
1	35	1.10	15.68	0.27	3.84	0.08	1.15	0.02	0.29	0.01	0.13
1.2	42			0.38	5.38	0.11	1.61	0.03	0.41	0.01	0.19
1.4	49			0.50	7.16	0.15	2.14	0.04	0.54	0.02	0.25
1.6	56			0.64	9.16	0.19	2.74	0.05	0.70	0.02	0.32
1.8	64			0.80	11.40	0.24	3.41	0.06	0.87	0.03	0.40
2	71			0.97	13.85	0.29	4.14	0.07	1.05	0.03	0.49
2.2	78			1.16	16.52	0.35	4.94	0.09	1.25	0.04	0.58
2.4	85			1.36	19.40	0.41	5.80	0.10	1.47	0.05	0.68
2.6	92					0.47	6.73	0.12	1.71	0.06	0.79
2.8	99					0.54	7.72	0.14	1.96	0.06	0.91
3	106					0.61	8.77	0.16	2.23	0.07	1.03
3.5	124					0.82	11.66	0.21	2.96	0.10	1.37
4	141					1.05	14.93	0.27	3.79	0.12	1.75
4.5	159					1.30	18.57	0.33	4.71	0.15	2.18
5	177							0.40	5.73	0.19	2.65
5.5	194							0.48	6.83	0.22	3.16
6	212							0.56	8.02	0.26	3.71
6.5	229							0.65	9.30	0.30	4.30
7	247							0.75	10.67	0.35	4.94
7.5	265							0.85	12.12	0.39	5.61
8	282							0.96	13.66	0.44	6.32
8.5	300							1.07	15.28	0.50	7.07
9	318							1.19	16.99	0.55	7.86
9.5	335							1.32	18.477	0.61	8.69
10	353							1.45	20.64	0.67	9.55
15	530									1.42	20.22

Volume Flow FAD		NPS Pipe size/ Inside diameter (mm)									
		1 1/2		2		2 1/2		3		4	
		40.89		52.50		62.71		77.93		102.26	
(m <sup>3</sup> /min)	(cfm)	(bar)	(psi)	(bar)	(psi)	(bar)	(psi)	(bar)	(psi)	(bar)	(psi)
0.8	28	0.01	0.09								
0.9	32	0.01	0.11								
1	35	0.01	0.13								
1.2	42	0.01	0.19								
1.4	49	0.02	0.25	0.01	0.07						
1.6	56	0.02	0.32	0.01	0.09						
1.8	64	0.03	0.40	0.01	0.11						
2	71	0.03	0.49	0.01	0.14						
2.2	78	0.04	0.58	0.01	0.17						
2.4	85	0.05	0.68	0.01	0.20	0.01	0.08				
2.6	92	0.06	0.79	0.02	0.23	0.01	0.09				
2.8	99	0.06	0.91	0.02	0.26	0.01	0.11				
3	106	0.07	1.03	0.02	0.30	0.01	0.12				
3.5	124	0.10	1.37	0.03	0.39	0.01	0.16				
4	141	0.12	1.75	0.04	0.50	0.01	0.21				
4.5	159	0.15	2.18	0.04	0.63	0.02	0.26	0.01	0.09		
5	177	0.19	2.65	0.05	0.76	0.02	0.31	0.01	0.11		
5.5	194	0.22	3.16	0.06	0.91	0.03	0.37	0.01	0.13		
6	212	0.26	3.71	0.07	1.06	0.03	0.44	0.01	0.15		
6.5	229	0.30	4.30	0.09	1.23	0.04	0.51	0.01	0.17		
7	247	0.35	4.94	0.10	1.42	0.04	0.58	0.01	0.20		
7.5	265	0.39	5.61	0.11	1.61	0.05	0.66	0.02	0.22		
8	282	0.44	6.32	0.13	1.81	0.05	0.75	0.02	0.25		
8.5	300	0.50	7.07	0.14	2.03	0.06	0.83	0.02	0.28	0.01	0.07
9	318	0.55	7.86	0.16	2.25	0.06	0.93	0.02	0.31	0.01	0.08
9.5	335	0.61	8.69	0.17	2.49	0.07	1.02	0.02	0.35	0.01	0.09
10	353	0.67	9.55	0.19	2.74	0.08	1.13	0.03	0.38	0.01	0.10
15	530	1.42	20.22	0.41	5.80	0.17	2.38	0.06	0.80	0.01	0.21
20	706			0.69	9.87	0.28	4.06	0.10	1.37	0.02	0.35
25	883			1.05	14.92	0.43	6.13	0.15	2.07	0.04	0.53
30	1059			1.46	20.90	0.60	8.59	0.20	2.90	0.05	0.75
35	1236					0.80	11.43	0.27	3.86	0.07	0.99
40	1412					1.03	14.63	0.35	4.94	0.09	1.27
45	1589					1.28	18.20	0.43	6.14	0.11	1.58
50	1765							0.52	7.46	0.13	1.92
55	1942							0.62	8.90	0.16	2.29
60	2118							0.73	10.46	0.19	2.69
65	2295							0.85	12.13	0.22	3.12
70	2471							0.97	13.91	0.25	3.57
75	2648							1.11	15.80	0.28	4.06
80	2824							1.25	17.81	0.32	4.58
85	3001							1.40	19.92	0.36	5.12
90	3177									0.40	5.69
95	3354									0.44	6.29
100	3530									0.48	6.92
150	5295									1.03	14.64

**Table 1. Global series – Air pipeline dimensions**

**NOTE**

The above table shows the pressure drops in 100m length schedule 40 steel pipe at 7 bar (abs)

**5.1.8 Oil fill procedure**

**Procedure for filling oil in a newly assembled machine**

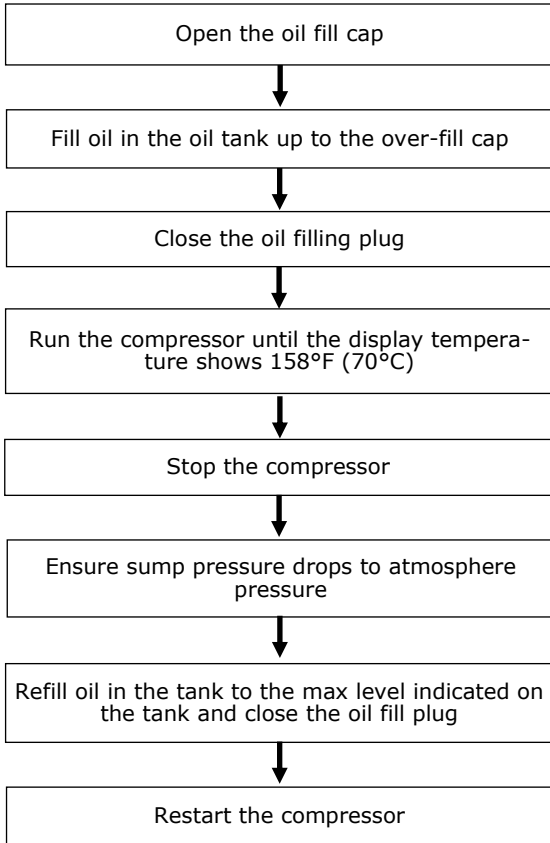

Sl. No.	Model	Volume of oil required Litres (gallons)	Initial fill Litres (gallons)	Second fill, after cranking Litres (gallons)
1	EN2 to EN5	1.6(0.4)	0.8(0.2)	0.8(0.2)
2	EN5x to EN11	6.2(1.6)	4(1.0)	2.2(0.6)
3	EN15	7.2(1.9)	4(1.0)	3.2(0.8)

**5.1.9 Procedure for changing oil in the compressor during service**

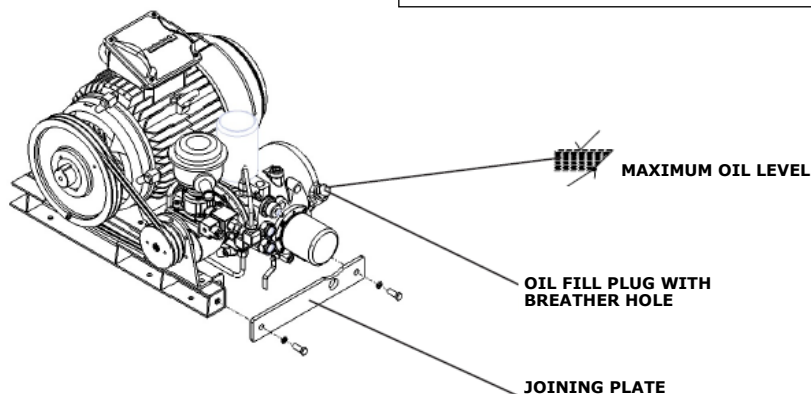
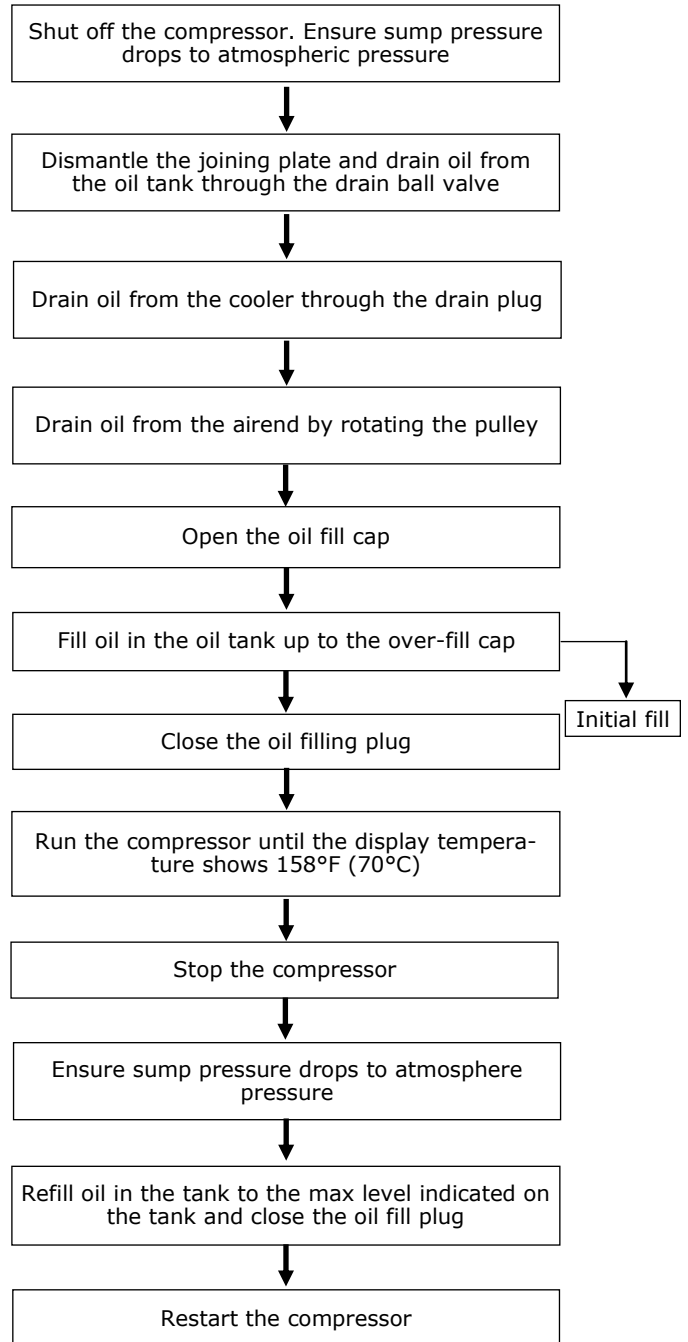

### 5.1.10 Direction of rotation

Check the direction of rotation of the main motor when starting the compressor for the first time. You do this by switching on the compressor and switching it off within 5 sec. Press the green start button to power on and the red mushroom stop button to power down the compressor. The motor must rotate in the clockwise direction when viewed from the main motor cooling fan side. If the direction of rotation is not correct, isolate the machine from the electrical lines and interchange any two phases. Restart the compressor and ensure that the direction of rotation of the main motor is counterclockwise and the fan motor is clockwise.

Switch on the compressor after ensuring all the above points and let it run at the rated speed.

In case of problems during the compressor operation, note the fault message in the controller display of the compressor. Refer to the Functional Description and Operation sections of this manual to know more about the fault.

If you hear any abnormal noise when you run the compressor, switch it off immediately and contact the ELGi service engineer.

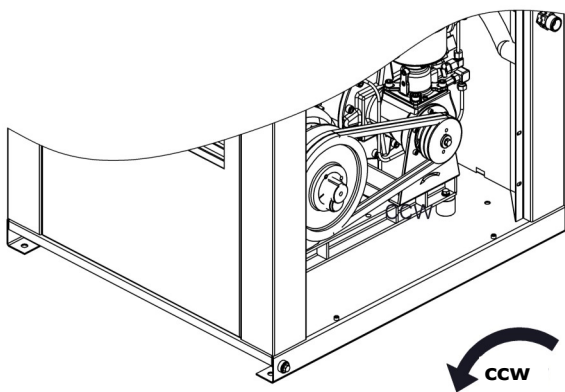

Follow all above points when you reinstall the compressor at a different location.

If the compressor had been in storage for an extended period before commissioning, contact the ELGi service engineer.



If you do not intend to use the compressor for a prolonged period, take special measures to ensure the protection of the following components:

1. The airend
2. The motor
3. The air oil sump or receiver tank

### 5.2.1 Airend

- Drain the oil from the air oil separator tank.
- Rotate the airend drive pulley by hand as you remove it.
- Block the connection port completely.
- Remove the intake filter and intake valve. Pour rust preventive oil (Castrol DWX 32 or an equivalent grade/brand) into the airend through the rotor intake area.
- Rotate the drive pulley by hand so that rust preventive oil spreads all over the bearings, seals, and other parts of the airend.
- Drain the rust-preventive oil by opening the drain plug fully.
- Refit the piping and belt.
- Ensure that all the openings are plugged to avoid dust entry.
- This procedure protects the airend for up to six months when the compressor is stored long. It must be repeated every six months during prolonged storage.

### 5.2.2 Motor

- Check the insulation of the motor winding.
- Remove any moisture in the motor.
- Check junction box terminals for tightness of wires.
- Apply grease on motor bearings.
- To prepare the motor for 1-year storage .

#### Other consumables

- Oil filter element
- Air filter element
- Separator element

### 5.2.3 Air-oil separator tank

- Drain the oil from the air-oil separator tank.
- Remove the entire tank from the compressor after disconnecting it from all hoses, the minimum pressure valve outlet line, control pulse lines, and control switches.
- Clean the tank using DWX 32 oil.
- The separator tank may now be stored for up to two years. Replace the separator element before using the compressor again.

### 5.2.4 Disposal of packing

The wood used in the shipping crates of the Encap series compressor is biodegradable.

The polyethylene covers wrapped around the compressor and the polystyrene packing provided around the electrical panels are not recyclable. These must be disposed of in accordance with prevailing environmental laws.

### 5.3.1 Safety system and interlocking device

#### 5.3.1.1 Discharge temperature sensor

This sensor enables the dryer to shut down the compressor if the discharge oil temperature mixture reaches a preset value of 230°F (110°C) ± 41°F (5°C). It resides on the airend outlet cover or the receiver tank.

#### 5.3.1.2 Minimum pressure valve

This valve resides at the outlet of the oil separator and maintains a minimum receiver tank pressure of about 58 psi. It facilitates proper air and oil separation, and oil circulation to the airend.

#### 5.3.1.3 Pressure relief valve

The pressure relief valve relieves pressure in the oil receiver tank when working pressure exceeds 217psi (15 bar).

#### 5.3.1.4 Overload relays for main motor and fan motor

These relays reside on the electrical control panel. They ensure that the compressor shuts off when power consumption exceeds a set value.

### 5.3.2 Operation control system

**Perform these tasks before starting the compressor:**

- Fill oil in the tank as per the oil filling procedure.
- Open all the doors and visually check the machine for suitable operation.
- Open the electrical panel at the front of the compressor and check whether the three phases with earth PE are connected securely.
- Check the necessary grounding line in the band/compressor base.
- Ensure that you commission the machine only in closed atmosphere air and on a level surface.
- Provide a clearance space of 3ft (1m) around the compressor.
- The machine should be commissioned on a levelled surface.
- Use only the recommended input cable size and fuse for the machine.
- Connect the correct cable size to the machine wings.
- For input power supply conditions, refer to 5.1.6.

### 5.3.3 Starting the equipment

Press the start button and check the direction of rotation of the end pulley.

### 5.3.4 Starting and normal operation mode

When you switch on the machine, the motor runs in DOL/star delta mode. Within a few seconds, the inlet valve opens and the compressor starts loading.

### 5.3.5 Unloading mode

After reaching the maximum cut-out pressure, the pressure sensor estimates the pressure and cuts off the solenoid electrical supply. At this stage, the blow down valve unloads the separator tank and the compressor starts to run in energy saving mode.

When the compressor runs continuously unloaded for 5 minutes in energy saving mode, it shifts to rest mode. Unless the demand for air increases, the machine does not restart. When air pressure falls, the compressor automatically starts loading.

### 5.3.6 Stopping

Press the STOP button (red) on the controller to stop the compressor.

### 5.3.7 Changing the compressor settings

Change the compressor settings using the tactile keypad and LCD panel on the controller. (Refer to the Neuron manual for details on the control panel and interpretation of the message.)

<b>Chapter</b>	<b>Page No.</b>
<b>6.1. Maintenance</b>	<b>6.2</b>
6.1.1 Maintenance intervals	6.2
6.1.2 Daily operation	6.3
6.1.3 Oil change over procedure	6.3
6.1.4 Air oil separator element (spin on type)	6.4
6.1.5 Oil filter (spin on type)	6.4
6.1.6 Oil cooler	6.4
6.1.7 Belt maintenance	6.4
6.1.8 Belt replacement	6.5
6.1.9 Belt and pulley data	6.5
6.1.10 Oil level check	6.7
6.1.11 Service procedure for minimum pressure valve	6.7
6.1.12 Service procedure for thermal valve	6.8
6.1.13 Condensate drain in tank	6.8
6.1.14 Procedure for draining the condensate	6.8
6.1.15 Anti vibration mount	6.8
<b>6.2. Troubleshooting</b>	<b>6.9</b>
<b>6.3. Decommissioning, dismantling &amp; putting out of service</b>	<b>6.14</b>
6.3.1 Waste disposal	6.14
6.3.2 Dismantling the compressor	6.14
6.3.3 Decommissioning the compressor	6.14
6.3.4 Disposal of consumables and replaced parts	6.14
<b>6.4. ELGi services</b>	<b>6.15</b>
6.4.1 ELGi customer care system (ECCS)	6.15
6.4.2 ELGi genuine spare parts	6.15
6.4.3 Air audit	6.15
<b>6.5. Appendix</b>	<b>6.17</b>
6.5.1 Conversion tables	6.17
6.5.2 Torque values	6.18
6.5.3 Service log book	6.19
<b>6.6. Disclaimers</b>	<b>6.21</b>

## 6.1.1 Maintenance intervals

Frequency	Part	Remarks
Daily	Oil level	Check
	MOS condensate	Check
	Warning / alarms	Check
	Condensate in AOS tank	Check
Weekly	Pre filter ( air intake, cooler, control panel)	Clean *
	Air filter element	Clean *
2000 hours or 6 months #	Oil & after coolers - air cooled (External)	Check & Clean *
	Oil	Sampling **
	Belt tensioning	Check & Re-tension
	Air filter element	Replace
4000 hours or every year #	50 Hz motor - 2 pole grease	Replace
	Pre filter ( air intake, cooler, control panel)	Replace *
	Oil filter	Replace
	Oil - Air lube XD / Air lube FG	Replace
	Air-oil separator element - Air lube XD / Air lube FG	Replace
	50 Hz motor ( 4 pole ) grease	Replace
	60 Hz motor ( > 25HP ) grease	Replace
	Return line sight glass / orifice / NRV	Check & Clean
	Return line strainer	Check & Clean
8000 hours or every 2 years #	Air-oil separator element - UT Synthetic	Replace
	Oil - UT Synthetic	Replace
	60 Hz motor ( ≤ 25HP ) grease	Replace
	Electrical connections	Check
	Pipe coupling element	Replace
	Intake valve kit	Replace
	Thermal Valve Kit	Check & Replace
	MPV kit	Replace
	BDV kit	Replace
	Solenoid valve	Replace
	Safety valve	Replace
Nylon tubes	Replace	
10000 hours	Belt	Replace
# - Whichever comes first	* - More frequently in dusty atmosphere	** - For USA / EUROPE region only

**Table 2. Maintenance intervals**

### NOTE

The above maintenance schedule is valid for standard reference conditions (Refer Table A) and standard working pressure (Refer technical data)  
 If the compressor is operating at low duty cycle, dusty environment, high humidity, high temperatures the maintenance interval will be shorter.  
 In the event of change in operating / environmental conditions, consult ELGi.



### REFERENCE CONDITIONS

Air inlet pressure (absolute)	bar(g) / psi(g)	1 / 14.5
Air inlet temperature	°C / °F	20 / 68
Relative humidity	%	0

**Table—A**

### NOTE

Depending on the ambient conditions and operating conditions of the compressors with variable frequency drive (i.e. with low ambient / low duty cycle), thermal valve element to be replaced with a higher rating if necessary.

### 6.1.2 Daily operation

Prior to starting the machine, check the oil level in the separator tank. (See Starting the compressor in the Operation section.) Should the level be low, add the necessary amount. If you need to add oil too frequently, it may indicate that a problem has developed which is causing this excessive loss. Refer to the Troubleshooting section (excessive coolant consumption) for a probable cause and remedy.

After a routine start has been made, observe the machine and monitor whether correct readings for that particular phase of operation are being displayed. Good practice is to perform a general check on the overall machine and instruments after the machine has warmed up, to ensure that the compressor is running properly.

### 6.1.3 Oil change over procedure



FROM Present Oil in the compressor	TO Change Oil type in the Compressor			
	ELGi Airlube XD (Mineral)	ELGi Airlube UT Synthetic	ELGi Airlube UT Synthetic plus	ELGi Airlube FG (Food Grade)
ELGi Airlube XD (Mineral) 000998066 - 5 Liters 000998053 - 20 Liters 000998055 - 208 Liters	NA	ELGI Air lube Cleaner Cleaner Oil 000998074 - 20 Liters	ELGI Air lube Cleaner Cleaner Oil 000998074 - 20 Liters	ELGI Airlube FG Cleaner* Cleaner Oil
ELGi Airlube UT Synthetic 000998092 - 5 Liters 000998090 - 20 Liters 000998093 - 208 Liters	NA	NA	No Cleaner required	ELGI Airlube FG Cleaner* Cleaner Oil
ELGi Airlube UT Synthetic plus 000998096 - 5 Liters 000998097 - 20 Liters 000998098 - 208 Liters	NA	NA	NA	ELGI Airlube FG Cleaner* Cleaner Oil
ELGi Airlube FG 000998079 - 5 Liters 000998078 - 20 Liters 000998077 - 208 Liters	NA	NA	NA	NA

\*Yet to be approved by ELGI

#### Procedure for change over of oil **Table 3. Oil change over procedure**

- Step 1 : Drain the present oil in the compressor completely
- Step 2 : Fill in cleaner oil (Ref. above table) to the recommended oil quantity in the compressor
- Step 3: Run the compressor for 500 hours and drain out the cleaner oil completely
- Step 4: Replace Oil filter and Air oil separator
- Step 5: Fill the compressor with new required oil type.

Sl. No.	Motor make	Grease	Part Number
1	ELGI	EM Unirex N3	015404151
2	SIEMENS		
3	WEG	EM Polyrex N2	015404152

**Table 4. Electric motor grease**

### 6.1.4 Air oil separator element (spin on type)

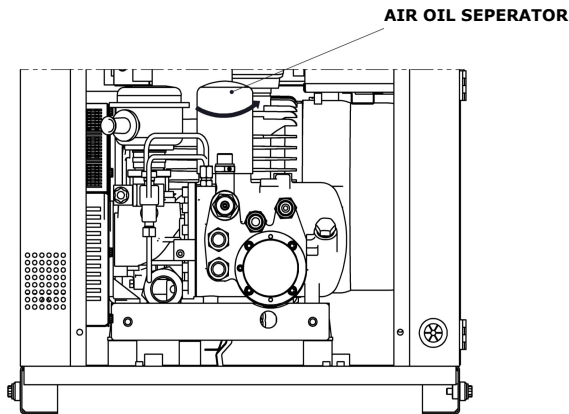

#### To disassemble the existing air oil separator

- Switch off and isolate the machine from the service line.
- Vent air oil separator tank pressure and allow the tank to cool for a few minutes.
- Hold the air oil separator outer shell by the removed strap belt and rotate it counterclockwise, until it completely unscrews.
- The hex adapter must be in the air oil separator head during disassembly.
- Check the recommended life of the air oil separator. If the recommended life is over, replace it with a new air oil separator.

#### Assembly of the new separator

- Ensure the gasket of the separator is not damaged.
- Clean the gasket-seating surface with a clean cloth.
- Apply a thin film of oil on the mating surface of the gasket.
- Replace the separator and rotate it clockwise by hand.
- Ensure no oil leaks from the mating surface. In case of leaking, check the gasket.
- After tightening by hand, rotate the separator further by hand for one and a half rotations.

### 6.1.5 Oil filter (spin on type)

#### Disassembly of existing oil filter

- Switch off and isolate the machine from the service line.
- Vent air oil separator tank pressure and allow the tank to cool for a few minutes.
- Allow it to cool for a few minutes.
- Hold the filter shell by the removed strap belt and rotate it counterclockwise, until it completely unscrews.

#### Assembly of new oil filter

- Ensure the gasket of the oil filter is not damaged.
- Clean the seating surface with clean cotton.
- Apply a thin film of oil on the mating surface of the gasket.

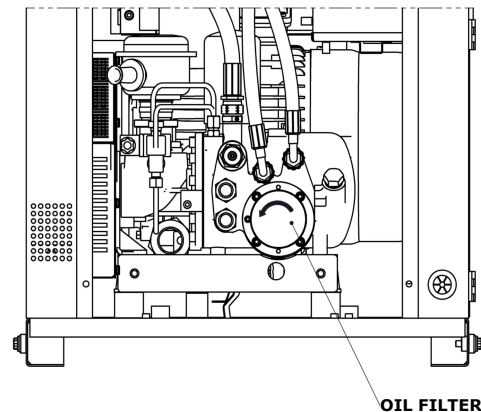

- Replace the oil filter and rotate it clockwise manually.
- After tightening, rotate it further by hand for one and a half rotations.
- Ensure no oil leaks from the mating surface.

### 6.1.6 Oil cooler

#### External cleaning of oil cooler

- Isolate the machine from the service line.
- Vent separator tank pressure before performing maintenance activities.
- Use compressed air less than 36 psi g (2.5 bar) to clean the outer surface of the cooler.
- Replace the vent cover.

#### Internal cleaning of cooler

- Use a 5 percent% (by volume) mixture of caustic soda in water. Circulate this mixture at 140oF (60°C) in the cooler for 5 hours. If required, increase the duration of circulation.

#### **WARNING**

*Do not burn or dispose of the cotton lint in the cooler fins. This may lead to deformation of the cooler. It may also lead to expansion of the cooler joints, resulting in leakage.*

### 6.1.7 Belt maintenance

The belts must be tensioned regularly in order to avoid compressor efficiency loss, belt slippage, and belt failures.

#### **The belts are re-tensioned once every 2000 hrs.**

To tension the belt:

- Switch off and isolate the machine from the service line.
- Isolate the machine from power supply.
- Unlock and remove the belt guard, rear panel, and motor side panel.
- Do not tension belts when hot. Let them cool down to <140°F (60°C) before performing belt maintenance.
- Loosen the lock nut mounted in the belt tension bolt.
- Screw the tension bolt clockwise.

- Check the belt tension.
- Tighten the lock nut.
- Switch on the machine and verify running.

### 6.1.8 Belt replacement

To replace belts:

- Switch off and isolate the machine from the service line.
- Isolate the machine from power supply.
- Unlock and remove the belt guard, rear panel, and motor side panel.
- Loosen the lock nut in the belt tension bolt.

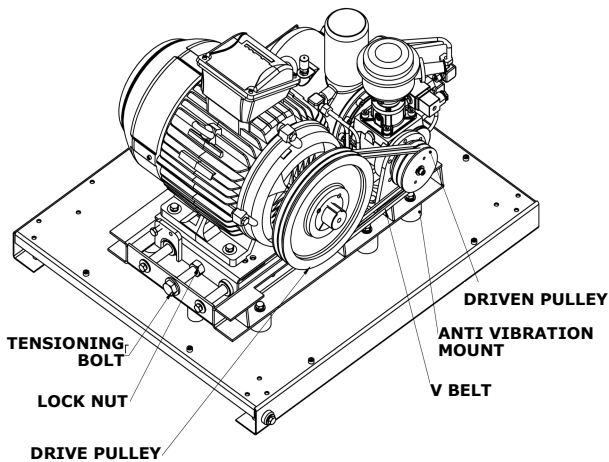

- Screw the belt tension bolt counterclockwise for five revolutions.
- Remove the old belts.
- Remove and inspect the grooves for wear and tear.
- Check the new belts to see if they are cracked or damaged. If ok, place the new belts in pulleys without damaging the belt.
- Tighten the tensioning bolt.
- Check the belt tension. Increase the tension if required.
- Tighten the lock nut.
- Switch on the machine and verify that the belt runs without wobbling.
- Let the machine run for 30 minutes.
- Switch off the machine and allow the belts to cool sufficiently.
- Check the belt tension again.
- Repeat the belt tensioning procedure to set the belts up to the required static belt tension as specified in the drive table .

### 6.1.9 Belt and pulley data

### Drive table

Procedure for assembling taper lock bush	
<b>Step 1</b>	Clean and de-grease the bore and taper surfaces of the bush and the tapered bore of the pulley. Insert the bush in the pulley hub and line up the holes. (Half thread holes must line up with half straight holes.)
<b>Step 2</b>	Lightly oil the grub screws and screw them; do not tighten yet.
<b>Step 3</b>	Clean and de-grease the shaft. Fit the pulley by using the taper bush on the shaft and place it in the desired position.
<b>Step 4</b>	When using a key, it should be first fitted in the shaft keyhole. There should be a top clearance between the key and the keyhole in the bore of the bushing.
<b>Step 5</b>	Using the proper hexagon socket wrench, gradually tighten the grub screws in accordance with the torques as listed in the table below.
<b>Step 6</b>	When the drive has been operating under Step load for a short period (half to one hour), check and ensure that the screws remain at the appropriate tightening torque.
<b>Step 7</b>	Fill the empty holes with grease in order to remove dirt.

Torque values for taper lock bushes			
Taper lock bush number	Grub screw used	Qty	Torque value (lb. Ft)
1008 1108	1/4" BSW	2	14.1
1310 1315	3/8" BSW	2	14.8
1210 1215	3/8" BSW	2	14.8
1610 1615	3/8" BSW	2	14.8
2012	7/16" BSW	2	22.9
1610 1615	1/2" BSW	2	35.5

Torque values for standard fasteners / fittings	
Bolt size	Torque lb ft
M6	7.8
M8	18.5
M12	64
G3/8	52
G3/8 ( For Aluminium interface)	44.2
HOSE Swivel nut	62.5

**DRIVE TABLE : EN2 - EN3 50HZ**

Sl. No	Belt & Pulley parameters	UOM	2.2 - 7	2.2 - 8	2.2 - 9.5	2.2 - 10	3.0 - 7	3.0 - 8	3.0 - 9.5	3.0 - 10	3.0 - 12.5
1	Drive pulley PCD	mm	125	125	85	85	160	160	118	125	95
2	Driven pulley PCD	mm	85	85	80	80	90	90	85	85	80
3	Type of belt	-	XPZ								
4	Pitch length of belt	mm	812	812	750	750	875	875	800	812	750
5	Static tension of NEW BELT	N	137-147	137-147	174-186	174-186	162-173	162-173	191-205	179-191	215-230
6	No of belts		1	1	1	1	1	1	1	1	1
7	Span length	mm	239	239	245	245	236	236	239	239	237
8	Mass of belt	g/m	60								

**DRIVE TABLE : EN4 - EN5 50HZ**

Sl. No	Belt & Pulley parameters	UOM	4.0 - 7	4.0 - 8	4.0 - 9.5	4.0 - 10	4.0 - 12.5	5.5 - 7	5.5 - 8	5.5 - 9.5	5.5 - 10	5.5 - 12.5
1	Drive pulley PCD	mm	160	190	140	140	118	224	224	200	190	170
2	Driven pulley PCD	mm	80	100	80	80	80	85	85	85	80	85
3	Type of belt	-	XPZ									
4	Pitch length of belt	mm	875	950	850	850	812	987	987	987	950	925
5	Static tension of NEW BELT	N	121-130	122-131	123-132	123-132	131-141	151-162	150-161	151-162	162-174	153-164
6	No of belts		2	2	2	2	2	2	2	2	2	2
7	Span length	mm	242	239	248	248	248	255	255	255	238	255
8	Mass of belt	g/m	60									

**DRIVE TABLE : EN5X - EN7 50HZ**

Sl. No	Belt & Pulley parameters	UOM	5.5X - 7	5.5X - 8	5.5X - 9.5	5.5X - 10	7.5 - 7	7.5 - 8	7.5 - 9.5	7.5 - 10	7.5 - 12.5
1	Drive pulley PCD	mm	190	190	125	125	200	200	170	170	180
2	Driven pulley PCD	mm	170	170	140	140	140	140	140	140	170
3	Type of belt	-	XPZ								
4	Pitch length of belt	mm	1212	1212	1037	1037	1180	1180	1112	1112	1180
5	Static tension of NEW BELT	N	147-158	147-158	147-158	147-158	178-191	178-191	190-203	190-203	192-206
6	No of belts		2	2	2	2	2	2	2	2	2
7	Span length	mm	323	323	311	311	322	322	312	312	315
8	Mass of belt	g/m	60								

**DRIVE TABLE : EN11- EN15 50HZ**

Sl. No	Belt & Pulley parameters	UOM	11 - 7	11 - 8	11 - 9.5	11 - 10	11 - 12.5	15 - 7	15 - 8	15 - 9.5	15 - 10	15 - 12.5
1	Drive pulley PCD	mm	200	200	180	180	190	190	180	190	190	180
2	Driven pulley PCD	mm	90	95	95	95	118	75	75	85	85	90
3	Type of belt	-	XPZ									
4	Pitch length of belt	mm	1112	1112	1080	1080	1140	1080	1037	1080	1080	1080
5	Static tension of NEW BELT	N	242-259	241-258	248-265	248-265	240-257	318-340	326-349	319-341	319-341	331-355
6	No of belts		2	2	2	2	2	2	2	2	2	2
7	Span length	mm	323	316	321	321	326	326	309	323	323	299
8	Mass of belt	g/m	60									



**DRIVE TABLE : EN2 - EN5 60HZ**

Sl. No	Belt & Pulley parameters	UOM	2.2 - 125	2.2 - 150	3.0 - 125	3.0 - 150	4.0 - 100	4.0 - 125	4.0 - 150	4.0 - 175	5.5 - 100	5.5 - 125	5.5 - 150	5.5 - 175
1	Drive pulley PCD	mm	95	90	170	125	150	140	150	140	200	224	170	132
2	Driven pulley PCD	mm	100	100	140	100	80	85	100	100	80	100	80	67
3	Type of belt	-	XPZ											
4	Pitch length of belt	mm	812	812	987	812	850	850	875	875	950	1037	875	812
5	Static tension of NEW BELT	N	94 - 100	97 - 104	153- 164	163- 175	159- 170	159- 171	156- 168	160 - 171	134 - 143	139 - 149	150- 161	137 - 147
6	No of belts	Nos	2											
7	Span length	mm	252	256	249	228	239	245	238	247	240	248	237	245
8	Mass of belt	g/m	60											

**DRIVE TABLE : EN7 - EN15 60HZ**

Sl. No	Belt & Pulley parameters	UOM	7- 100	7- 125	7- 150	7- 175	11- 100	11- 125	11- 150	11- 175	15- 100	15- 125	15- 150	15- 175
1	Drive pulley PCD	mm	140	170	150	132	150	160	150	150	160	160	170	150
2	Driven pulley PCD	mm	112	140	140	140	80	95	95	112	67	80	90	85
3	Type of belt	-	XPZ											
4	Pitch length of belt	mm	1037	1140	1080	1080	987	1037	1037	1037	987	1037	1037	1037
5	Static tension of NEW BELT	N	181- 194	185 - 198	182- 198	183 -197	245 - 263	238- 255	243- 260	240- 258	318- 338	309- 331	301- 323	317- 340
6	No of belts		2	2	2	2	2	2	2	2	2	2	2	
7	Span length	mm	320	326	312	326	310	316	324	312	308	327	311	332
8	Mass of belt	g/m	60											

**DRIVE TABLE : EN Series 115 psi 60 HZ**

Sl. No	Belt & Pulley parameters	UOM	2.2	3.0	4.0	5.5	7	11	15
1	Drive pulley PCD	mm	90	125	170	170	140	132	150
2	Driven pulley PCD	mm	90	90	95	75	118	75	67
3	Type of belt	-	XPZ						
4	Pitch length of belt	mm	750	812	925	875	1037	987	987
5	Static tension of NEW BELT	N	80-86	96-103	124-133	151-162	181-194	259-278	321-343
6	No of belts		2	2	2	2	2	2	2
7	Span length	mm	234	237	252	241	316	330	321
8	Mass of belt	g/m	60						

### 6.1.10 Oil level check

- Conduct periodic checks on the oil level.
- Top up oil if the oil level goes below the level shown above.

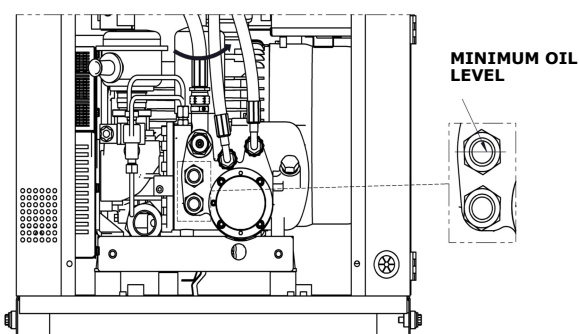

### 6.1.11 Service procedure for minimum pressure valve

Before disassembling the complete valve from the airend,

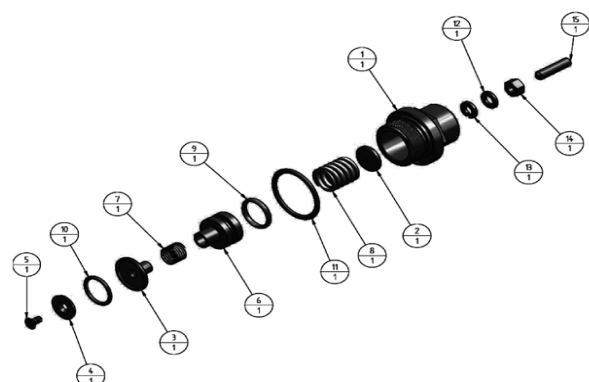

it is absolutely necessary to remove parts 12-15. Else, the threaded part of body 1 will be damaged. Before removing it, check the distance between the end of part 15 and the top of part 1..

- Remove the complete valve from the airend.
- Remove and discard O-rings 9 and 11.
- Remove screw 5 and part 4.
- Replace O-ring 10 with a new O-ring from the repair kit. Replace part 4 and screw 5.
- Place the new O-rings 9 and 11.
- Apply teflon grease on the interior of part 1.
- Reassemble all components.
- Reassemble parts 12-15. Return part 15 to the same position.

**6.1.12 Service procedure for thermal valve**

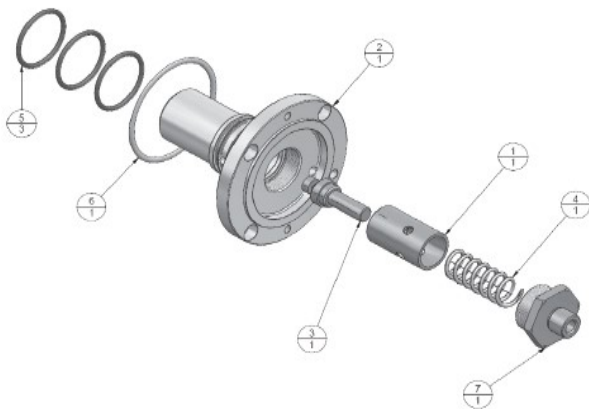

- Disassemble the oil filter.
- Disassemble the screw that fixes part 2.
- Place and tighten the screws inside the removal tap of part 2.
- Remove the complete valve.
- Remove and discard O-rings 5 and 6.
- Remove nipple 7.
- Remove parts 4 and 3.
- Replace parts 3 and 4 with new parts from the service kit.
- Replace nipple 7.
- Replace the new O-rings 5 and 6.
- Apply teflon grease on O-rings 5 and 6.
- Reassemble the complete valve.

**6.1.13 Condensate drain in tank**

If the duty cycle of the compressor (running hours) per day is less than 16 hours, check for water condensation in the air oil separator tank. When the compressor switches off, the hot air inside the tank might condense when the surrounding temperature lowers. In such cases, drain the

condensate from the separator tank weekly once or twice depending on the moisture quantity. The condensate, which is denser than oil, will settle at the lower part of the tank.

**6.1.14 Procedure for draining the condensate**

To drain the condensate in the tank:

- Switch off and isolate the machine from the service line.

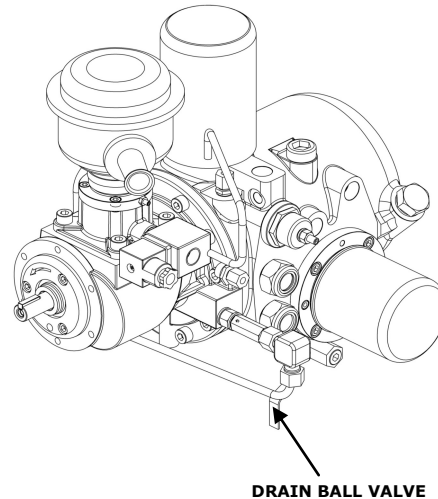

- Unscrew the drain plug from the oil drain line.
- Slightly open the drain ball valve.
- Check for water in the valve outlet. Close the valve immediately after draining the water to prevent leakage of more oil.
- Replace the drain plug. Tighten it firmly to avoid leaks.
- Dispose of the drained condensate as per the local environmental procedure.

**6.1.15 Anti Vibration Mount**

Anti Vibration Mount should be replaced during major           ◆◆◆           overhaul of airend or motor. If no such situation, replace AVM every 5 years

## 6.2 Troubleshooting

This guide includes the most likely problems with possible causes. In case of a problem, follow the diagnosis in sequential order as mentioned in the following charts. Before performing any work in this unit, be sure to cut off electrical supply, depressurize the entire compressor, and isolate the unit.

Problem	Cause	Solution (go sequentially)
<b>Compressor not starting</b>	Power supply not available	Restore incoming power supply.
	Incoming voltage is below limit	(1) Correct the incoming voltage.
		(2) Ensure the isolator is within 5m from the compressor.
		(3) Ensure sufficient power backup.
		(4) Select and use the correct cable size.
	Emergency stop switch in pushed condition	Rotate counterclockwise and release.
	Emergency stop switch malfunction	Clean or replace the emergency switch.
		Tighten the wires at terminals.
	Isolator fuse blown	(1) Select the correct fuse rating from the selection chart.
		(2) Check and correct the short circuit within the control panel.
		(3) Dedicated isolator to be provided to the compressor.
		(4) Check and correct the motor winding/body short after the megger test.
	Incoming phase-to-phase voltage imbalance of more than 5V	Correct incoming voltage.
		Adjust main incoming transformer tapping.
		Correct the power factor to less than unity.
	Incoming phase-to-earth voltage imbalance of more than 5V	Correct incoming voltage.
	Control MCB malfunction	Replace MCB
Control fuses inside compressor control panel blown	Check for any short circuit or loose connection.	
	Replace the solenoid valve/control transformer if defective.	
	Replace the glass fuse (2A for Neuron, 1A for the control circuit).	
Control transformer fuse blown	Replace the control transformer if defective.	
	Replace the glass fuse (0.25A for Neuron, 0.5A for the control circuit).	
No power supply to Neuron controller.	(1) Replace control transformer fuses.	
	(2) Ensure tight connection of the 24V power supply connector to Neuron.	
	(3) Replace the control transformer (50VA).	
No display in Neuron controller	(1) Replace the control transformer (50VA).	
	(2) Replace the control fuse.	
	(3) If 24V power supply to Neuron is okay, then replace with a new Neuron micro controller.	

Problem	Cause	Solution (go sequentially)
<b>High discharge oil temperature</b>	Oil level is low	(1) Check and refill oil to correct the level (in stopped condition).
		(2) Refer to the diagnosis procedure for high oil carry-over.
		(3) Arrest oil leaks.
		(4) Ensure the correct grade of oil is used.
	Room temperature is higher than outside ambient temperature by 30°C (86°F)	Improve ventilation in the compressor room.
	Oil cooler clogged externally	Clean the cooler assembly/pre-filter mesh (if available) externally by first using a fibre brush and then by blowing compressed air at 87 psi g (6 bar).
		For sticky dust, remove the cooler, close all the cooler ports with dummy plugs, and do a water-wash with soap oil.
		Install the cooler pre-filter mesh.
	Cooling fan rotating in wrong direction.	Check and correct the wiring connection to the cooling fan.
		Replace with the correct fan type.
	Check fan motor fuse	Replace the fuse if blown.
		Replace with the 2A fuse.
	Cooling fan not working.	Check and ensure the neutral connection is complete.
	Temperature sensor malfunction	Replace the sensor.
		Tighten/recrimp the connection with the adaptor.
	Oil filter clogged	Replace the oil filter.
		If required, replace the oil (based on the condition of oil) and run the compressor.
	Thermal valve malfunctioning	Replace the thermal valve element.
	Oil injection orifice choked or improper size	Clean the oil injection orifice.
		Replace with correct size.
Air filter clogged	Clean or replace the air filter.	
Air-oil Separator element clogged	Verify pressure drop is less than 14.5 psi g ( 1bar).	
	Replace oil.	
	Replace separator element.	
Poor quality of oil	Replace oil.	
Oil cooler clogged internally	Check for pressure drop across the oil cooler if less than 21 psi g (1.5 bar).	
	Check and clean the cooler internally with 20L of isopropyl alcohol + toluene mixture in the 1:1 ratio and circulate for 4 hours with external 1 HP pump.	
	Refit the cleaned cooler and, if required, replace oil (based on the condition of oil) and run the compressor.	

<b>Problem</b>	<b>Cause</b>	<b>Solution (go sequentially)</b>
<b>High oil carry-over</b>	High oil level	Drain excess oil and maintain the recommended oil level.
	Oil is milky	Replace oil and maintain the recommended level.
	Scavenge return line tube clogged	Remove and clean the clogged scavenge return line tube.
		Replace the internal pipe.
	High discharge oil temperature (DOT)	Refer to the diagnosis procedure for high DOT.
	Improper grade of oil	Use ELGi recommended air lube oil.
	Separator punctured/collapsed	Replace with a new separator.
	Separator element bonding ruptured	Replace with a new separator.
	Compressor runs at lower pressure than normal.	1) Use a suitable higher capacity compressor or match demand to compressor capacity.
	Compressor runs at lower pressure than normal.	2) Arrest all line leakages.
	Minimum pressure valve (MPV) opens earlier than the specified opening pressure of 65 psi g (4.5 bar).	Replace MPV kit/assembly.
	Neuron microcontroller pressure settings: 1) Unload pressure set value is above specification. 2) High tank pressure set value is below specification.	Check and correct unload pressure and high tank pressure values in the Neuron micro-controller.
		1) Check and replace the intake valve kit if required.
Intake valve malfunction	2) Check the solenoid valve and clean or replace if required.	
<b>High tank pressure</b>	Intake valve malfunction	3) Check and replace the actuator kit if required.
	BDV malfunction	Check/replace.
		Open the outlet ball valve.
		Check the solenoid valve and clean or replace if required.
	Neuron microcontroller malfunction	Replace the Neuron microcontroller.
	Pressure transmitter malfunction	Replace the pressure transmitter.
	MPV stuck up (check with pressure gauge in AOS tank )	Replace the MPV kit.
	Separator element choked	Replace the separator element.
	Pressure transmitter malfunction	Replace pressure transmitter
	MPV stuck up (check with pressure gauge in AOS tank )	Replace MPV kit.
Separator element choked	Replace separator element	

Problem	Cause	Solution (go sequentially)
<b>Loading/unloading problem</b>	No control air supply to solenoid valve	Replace/connect
	Solenoid valve malfunctioning	1. Replace the solenoid valve assembly.
		2. Clean the orifice.
	No electrical supply for energizing the solenoid valve	Replace the Neuron microcontroller.
	Intake valve malfunctioning	Check and replace the intake valve kit.
	Blow-down valve malfunctioning	1. Clean or change the BDV assembly.
		2. Clean the orifice.
	MPV malfunctioning	1. Check and change the MPV kit.
		2. Check and change the MPV assembly.
	1. Air requirement is more than compressor capacity	1. Replace the compressor. 2. Arrest all pipeline leakages.
	3. Excess pressure drop in pipeline	1. Replace the compressor. 2. Arrest all pipeline leakages.
	Pressure transmitter malfunction	1. Tighten the lap cable.
	Pressure transmitter malfunction	
	Pressure transmitter malfunction	
	Pressure transmitter malfunction	4. Replace the Neuron microcontroller.
Replace the Neuron microcontroller.		
Disable 'unload mode' in the operator settings of the Neuron microcontroller.		
4. Replace the Neuron microcontroller		
Malfunction of R04 relay (loading/ unloading relay) in Neuron microcontroller	Replace Neuron microcontroller	
Unload mode enabled in Neuron microcontroller	Disable 'unload mode' in operator settings of Neuron microcontroller	

Problem	Cause	Solution (go sequentially)
<b>Pressure not built up</b>	Inlet air pre-filter mat clogged	Clean/change the pre-filter mat by following these steps: Switch off the machine. Squeeze and pull out the pre-filter mat from the canopy. Clean the pre-filter with compressed air at less than 7 bar g. Refit the filter after cleaning.
	Clogged air filter element	Clean/change air filter element
	1. Air requirement is more than compressor capacity	1. Replace the compressor. 2. Arrest all pipeline leakages.
	2. Working pressure is lower than required application pressure	
	3. Excess pressure drop in pipeline	
	No control air supply to solenoid valve	Replace / connect the control line tubes.
	Solenoid valve malfunctioning	1. Replace the solenoid valve assembly.
		2. Clean the orifice.
	No electrical control supply to solenoid valve	Replace the microcontroller.
	Intake valve malfunctioning	Check and replace the intake valve kit.
	Blow-down valve malfunctioning	1. Check and change the BDV assembly.
		2. Clean the orifice.
	MPV malfunctioning	1. Check and change the MPV kit.
		2. Check and change the MPV assembly.
Separator element choked (increase in pressure drop across separator)	Replace the separator element. If required, replace oil (based on the condition of oil) and run the compressor.	
	2. Change pressure regulator assembly.	
Actuator failure (applicable only to EG 55 to EG 250)	Check and change actuator / kit / assy.	
Separator element choked (increase in pressure drop across separator)	Replace separator element. If required replace the oil (based on condition of the oil) and run the compressor.	

If you do not intend to use the compressor or any of its parts, you must dismantle and put it out of service. These tasks must be performed in compliance with the standards in force of that particular country.

### 6.3.1 Waste disposal

- Use of the compressor generates waste. The residues from agricultural, industrial, crafts, commercial, and service activities must be treated as waste, which needs to be disposed of properly. Deteriorated or obsolete machines are also classified as waste.
- Special attention must be given to active carbon filters as they cannot be included in urban waste. Observe the waste disposal laws in force where the compressor is used.
- It is mandatory to record loading or unloading of exhausted oils, obsolete machines, and toxic harmful wastes that derive from heavy or light industry processes.
- It is especially important that exhausted oils be disposed of in compliance with the laws in the countries of use.

### 6.3.2 Dismantling the compressor

- Dismantle the compressor in accordance with all the precautions imposed by the laws in force in the country of use.
- Before dismantling, request an inspection by the relevant authorities. Disconnect the compressor from the electrical system.
- Eliminate any interfaces the compressor may have with other machines, making sure that interfaces between remaining machines are unaffected.
- Empty the air oil tank containing the lubricating oil and store in compliance with the laws in force.
- Proceed with the disassembly of the individual compressor components and group them together according to the materials they are made of: Steel, Stainless Steel, Aluminum and plastic parts.
- Then scrap the machine in compliance with the laws in force of the country of use.

### 6.3.3 Decommissioning the compressor

- Remove the foundation for the compressor.
- Unplug the power cable entry to the compressor.
- Drain the oil from the cooler and air oil tank. Dispose of it properly.
- Make sure all the compressed air is vented out through ball valves and safety devices residing in the compressor.
- Ensure that all the external supply lines have been properly disconnected from the compressor before decommissioning.

### 6.3.4 Disposal of consumables and replaced parts

- The moisture condensate separated from the compressed air contains oil particles. Disposal of condensate and the filter element is to be performed in accordance with the pollution control norms prevailing at the time of compressor installation or use.
- Parts of the compressor that are replaced have metal and rubber components. These may be recycled and disposed of according to pollution control regulations, respectively.
- Rubber items such as AVMs, coupling elements, and O-rings should be disposed of and replaced before running again.

#### NOTE

*ELGi is not responsible for the disposal of old oil or condensate. It is the responsibility of the customer to dispose of the foregoing in accordance with local environmental statutory laws.*

#### WARNING

*The compressor does not give any warnings during short operating times. If it is operated below the dew point and moisture, then condensate may mix with oil. This will reduce the lubricating quality of the oil and lead to damage of the compressor.*





### 6.4.1 ELGi customer care system (ELGi CCS)

ELGi provides dedicated customer care and after-sales support through the ELGi customer care system (CCS), a computerized system developed in-house. The CCS aims to minimize the time taken to resolve customer complaints.

#### Service requests/complaints

The CCS toll-free telephone number 1800-425-3544 (accessible within India through BSNL and MTNL lines) takes the customer's call to our centralized customer care center in Coimbatore. Customers can register their service requirements or complaints here.

A unique tracking number is generated for each call logged by the CCS. The customer receives an automatic e-mail acknowledgement with the tracking number and details of the call for reference.

A service engineer is assigned to the call, and the date and time of the engineer's visit are communicated to the customer by e-mail. Every requirement or complaint must be resolved and closed in the CCS within a specified time limit, failing which the complaint is automatically brought to the notice of the manager. If the issue remains unresolved, it will get escalated to the managing director. The CCS ensures that not only the customer complaints are logged but they are also attended to on time, every time.

#### Enquires

A number of calls received by the CCS relate to customer queries regarding products and spare parts. The details are noted, and basic information on product specifications and usage are provided. The caller is then referred to a salesperson at the head office or the appropriate branch for follow-up.

#### The CCS database

The CCS also creates a database of customers, adding details of every new customer who calls, thereby building a large pool of installation details. These details are used to provide value-added services to improve customer satisfaction with ELGi products.

#### CCS-working hours

The ELGi CCS works for six days a week from 08:30 to 21:30 IST (Monday to Saturday).

#### Multi-lingual capability

The coordinators at the CCS are multi-lingual. They can handle calls in English and all the major regional languages of India.

**Coverage:** The CCS toll-free number 1800-425-3544 is accessible from the following areas:

- **Southern Region:** Tamil Nadu, Karnataka, Kerala, Puducherry, Andhra Pradesh, Telangana, Andaman & Nicobar Islands.
- **Western Region:** Maharashtra, Gujarat, Madhya Pradesh, Goa, Lakshadweep Islands.
- **Eastern Region:** Orissa, Chhattisgarh, Jharkhand, West Bengal, Bihar and the North-Eastern states.

- **Northern Region:** Rajasthan, Uttar Pradesh, Delhi, Haryana, Punjab, Uttaranchal, Himachal and Jammu & Kashmir.

**Contact Numbers:** You can contact CCS also with the following numbers:

**Telephone:** 0422-2589206 / 241 / 242 / 243/ 244 / 245 / 97900 21100

**Fax:** 0422-2589240

Please send the following details to the mail, thus enable us to take immediate action.

1. Name of the customer
2. Compressor model
3. Fab. number
4. Contact person name
5. Phone number
6. Nature of complaint
7. Hour meter reading

You may use the CCS by sending e-mail to: **ccs@elgi.com**

#### Customer satisfaction survey

If you have used the CCS, you may be contacted for your feedback on our after-sales support. Your response helps ELGi to improve its service.

#### International customers:

Refer contact information at the end of this manual book.

### 6.4.2 ELGi genuine spare parts

When ordering spare parts, refer to the lists provided in the parts manual and identify the part number. Specify the part number and quantity, in addition to the name plate details. Global support center of ELGi ensures the supply of the quality spares on time. Ensure that you are using the genuine spare parts so that your Compressor will be working efficiently and effectively. Refer to section 6.1.3 for details on need of using genuine spares.

Please contact our After sales team for any compressor accessory requirements like VFD, Air-Dryer, etc.

### 6.4.3 Air audit

We extend our proven capabilities in energy efficiency initiatives by carrying out air audits for our customers.

ELGi conducts audits and trains end users in key energy oriented functional areas. The audit reports prepared by ELGi experts' team include recommendations on short, medium and long term measures for energy conservation, along with financial estimates and analysis for implementation.

This air audit objective is to provide the customer:

- The framework for systematic collection of data relevant to the efficient operation of compressed air systems.
- A thorough analysis about the performance of the compressed air system, identifying potential electricity savings and to provide sound recommendations for implementation of energy efficiency initiatives.

Data analysis will be comprised of the information about different areas such as air leakages, inappropriate use of compressed air, compressed air system network,

compressed air system supply including compressor internal maintenance conditions and even more.

The final report issued to the customer end will serve the purpose of assisting concise, consistent and complete presentation of the analysis, findings and recommendations arising from a compressed air system audit.

Depending on the measurement, reporting and cost requirements from the customer end, the intensity in level of audit (base level or investment level) will be decided.

Also post implementation monitoring after air audit will be provided if requested from the customer end.

For further information on air audit contact ELGi.

**E-Mail:** [ccs@elgi.com](mailto:ccs@elgi.com)



## 6.5.1 Conversion tables

Description	From	To	Multiply by
Length (L)	Inches	Millimetres	25.4
	Metres	Inches	39.37
	Feet	Millimetres	304.8
	Metres	Feet	3.281
	Inches	Thou	1000
	Millimetres	Micrometres	1000
Area (A)	Square metres	Square feet	10.765
	Square feet	Square inches	144
	Square inches	Square millimetres	645.16
Volume (V)	Cubic metres	Cubic feet	35.315
	Cubic feet	Cubic inches	1728
	Cubic metres	Litres	1000
	Cubic feet	Litres	28.32
	US gallons (liq)	Litres	3.785
	Imperial gallons (liq)	Litres	4.546
Volumetric flow (Q)	Cubic feet per minute (cfm)	Cubic metres per hour (m <sup>3</sup> /h)	1.6988
	Cubic feet per minute (cfm)	lpm	28.32
	Cubic metres per hour (m <sup>3</sup> /h)	lpm	16.667
	Cubic metres per minute (m <sup>3</sup> /min)	lps	16.667
Mass (M)	Kilograms	Pounds	2.205
	Kilograms	Grams	1000
	Kilograms	Ounces	35.27
Pressure (P)	kg f/cm <sup>2</sup> g	psi g	14.223
	psi g	Pascal	6895
	bar g	kg f/cm <sup>2</sup> g	1.0197
	bar g	psi g	14.503
	psi g	kg f/cm <sup>2</sup> g	0.0703
Temperature (T)	Degree Celsius (°C)	Degree Fahrenheit (°F)	°F = 9(°C)/5 + 32
	Degree Celsius (°C)	Kelvin (K)	K = °C + 273.15
	Degree Fahrenheit (°F)	Degree Rankine (°R)	°R = °F + 460
Heat (q), Work (W), Energy (E)	ft-lb f	Joules	1.35582
	ft-lb f	Btu	0.001285
	Joules	Calories	0.2388
	Btu/h	Calories/h	252
	Kilowatts	Btu/h	3411
Power (P)	Metric horsepower	Kilowatts	0.7355
	Imperial horsepower	Kilowatts	0.7457

Table 3: Conversion table

## 6.5.2 Torque values

The tightening torque values for bolts and screws used in ELGI Compressors are provided in this section for reference. The tolerance for the torque values is (-) 10% from the given value.

Thread size*	Tightening torque (N-m)	Tightening torque (lb-ft)
M4	2.9	2.13
M5	5.7	4.20
M6	9.8	7.22
M8	24	17.7
M10	47	34.66
M12	81	59.73
M16	197	145.28
M20	385	283.93

**Table 4: Metric hexagonal head bolts and screws**

Thread size (inches)	Tightening torque (N-m)	Tightening torque (lb-ft)
¼"	45	33.19
½"	85	62.69
¾"	170	125.38
1"	330	243.39
1¼"	430	317.15
1½"	510	376.15

**Table 5: BSP threads**

Thread size (inches)	Tightening torque (N-m)	Tightening torque (lb-ft)
9/16"	149	109.8875
7/8"	579	427.0125

**Table 6: UNF threads**

\* Property class of 8.8 only





Please read this document and the warranty terms accompanying the product carefully before using our product. By purchasing our product, you agree that you will assume total responsibility and risk for your use of the product. The warranty terms of the product have been provided separately.

1. ELGi is not liable for failure of the compressor ( hereinafter "compressor" or "product") to perform its obligations if such failure is as a result of Acts of God (including but not limited to fire, flood, earthquake, storm, hurricane or other natural disaster), war, invasion, act of foreign enemies, hostilities (regardless of whether war is declared), civil war, rebellion, revolution, insurrection, military or usurped power or confiscation, terrorist activities, nationalization, government sanction, blockage, embargo, labour dispute, strike, lockout or interruption or failure of electricity or telephone service and any other reasons beyond ELGi's control.
2. ELGi does not take responsibility for any damage or injury resulting from neglecting the safety instructions, warnings, cautions, precautions, or non-observance of the normal caution and care required for installation, operation, maintenance and repair of the product, even if not expressly stated, and such instances are specifically disclaimed by ELGi.
3. The entire literature including product description or any other information in this manual exclusively belongs to ELGi and is subject to copyright. No person has any right to copy, modify, distribute, transmit, display, perform, reproduce, publish, license, create derivative works, transfer or sell any information, or deal with the same in any other manner, without the knowledge and written concurrence of ELGi, violation of which would amount to infringement of rights of ELGi and would necessitate legal action.
4. The information published in this manual may include inaccuracies, or typographical errors. Changes may be periodically added to the information herein. Any changes/improvements may also be made to the products stated in this manual and ELGi is not liable if the readers are not updated with information.
5. Likewise ELGi is responsible only till the point of first sale to the ultimate customer and not thereafter and only if the product is purchased from authorized dealers of ELGi. ELGi disowns liability on account of purchase of any second hand product or purchase otherwise from unauthorized dealers. ELGi shall not be liable for any indirect, incidental, punitive, special or consequential losses or damages including any loss of profit, loss of production, loss of income or contract, loss of goodwill, expected savings or business relationships, arising out of or in any way connected with the usage of the product or information in this manual.
6. In no event ELGi shall be liable for any claims or loss having a value higher than the original purchase price of the product sold by ELGi or its network of authorised dealers.
7. These Disclaimers and the contents of this manual shall be subject to the laws of India and any disputes pertaining to this manual or anything stated therein or any product stated therein is subject to the exclusive jurisdiction of the courts in Coimbatore, Tamil Nadu, India.
8. No liability in connection with the product will accrue to ELGi,
  - If any welding or related operation involving heat is carried out in the compressor. Never weld or modify any parts including pressure vessels.
  - If any damages to the product directly or indirectly arise due to long storage (6 months) of product and subsequent corrosion of internal parts and which leads to fire or malfunctioning of the product.
  - If the compressor package and its accessories are installed in such a way to allow moisture, rain, freezing temperature or sun damage to affect the safe operation of the unit.
  - If the person who operates / maintains the compressor does not adhere to all work related safety practices and regulatory requirements.
  - If unauthorized personnel other than ELGi authorized or trained personnel carries out commissioning, installation, operation, maintenance and any repair work on the compressor.
  - If the compressor and the compressed air are used for unintended use or are misused.
  - If the compressor is operated below or in excess of its pressure and temperature limits.
  - If the compressor "ON/ OFF" switch is operated through remote control situated away from the compressor location without giving any adequate notice / alarm before starting the product .

© Copyright ELGi Equipments Limited, India 2018. All Rights Reserved.









# Controller Manual

Neuron XT

Version 3.6  
Dec 2021

<b>Contents</b>	<b>Page No.</b>
<b>Abbreviations used</b>	<b>7.4</b>
<b>7.1. Technical specification</b>	<b>7.5</b>
<b>7.2. Installation instruction</b>	<b>7.7</b>
7.2.1 Equipment's safety	7.7
7.2.1.1 Static discharge warning	7.7
7.2.1.2 Assembly	7.7
7.2.1.3 Electrical connection	7.7
7.2.1.4 Power supply	7.7
7.2.2 General instruction	7.7
<b>7.3. Front view</b>	<b>7.8</b>
7.3.1 Terminal connection	7.8
<b>7.4. Neuron-XT salient features</b>	<b>7.8</b>
7.4.1 Home screen display	7.8
7.4.2 Records (view-> fault report)	7.8
7.4.3 Remote function (both MODBUS as well as digital input)	7.8
7.4.4 Other interfaces and communication	7.8
7.4.5 Safeguard	7.8
<b>7.5. Input output description</b>	<b>7.9</b>
7.5.1 X01: Power supply	7.9
7.5.2 X02: Digital inputs	7.9
7.5.3 X03: Relay output	7.9
7.5.4 X04: Relay output	7.9
7.5.5 X05: Single phase detector	7.10
<b>7.6. Main screen</b>	<b>7.11</b>
7.6.1 Important machine settings for users	7.12
<b>7.7. Menu structure</b>	<b>7.14</b>
7.7.1 View	7.14
7.7.1.1 Operator	7.14
7.7.1.2 Fault report	7.14
7.7.1.3 Service time	7.15
7.7.1.4 Cumulative time	7.15
7.7.2 Operator	7.15
7.7.2.1 Machine	7.15
7.7.2.2 Maintenance	7.16
7.7.2.3 Language	7.16
7.7.3 Service	7.17

<b>Contents</b>	<b>Page No.</b>
7.7.3.1 Calibration (offset)	7.17
7.7.3.2 Relay	7.17
7.7.3.3 Temperature	7.17
7.7.3.4 Auto drain valve	7.17
7.7.3.5 Maintenance	7.17
7.7.3.6 Self-test	7.17
7.7.3.7 Unload mode	7.17
7.7.3.8 Digital input	7.18
7.7.4 Customer care	7.18
<b>7.8. Data interface</b>	<b>7.18</b>
<b>7.9. Troubleshooting</b>	<b>7.19</b>
<b>7.10. Construction</b>	<b>7.20</b>
7.10.1 Dimension drawing	7.20
<b>7.11. Neuron XT quick reference</b>	<b>7.21</b>
<b>7.12. Revision details</b>	<b>7.24</b>

Dis. Pressure	Discharge pressure
Dis. Temperature	Discharge temperature
HSP	High sump pressure
Temp	Temperature
DPAF	Differential pressure air filter
DPOF	Differential pressure oil filter
AF	Air filter
OF	Oil filter
Min	Minimum
Max	Maximum
UL	Unload
En	Enable
Dis	Disable
L	Load
St	Stop
F	Fault
R	Run
Sby	Standby
STC	Start count
LDC	Load count
Ph Fail	Phase failure
Pr	Pressure
Tr	Temperature
DCS	Distributed control system
PR	Pressure
MMOL	Main motor overload
OL	Overload
NC	Not connected
RST	Restart time
DTR	Delta to run
RTS	Run to stop
REM	Remote
RTU	Remote terminal unit

The following are the specifications that you must be familiar with for Neuron XT

Definition	: Pre programmed logic controller
Function	: Compressor control system
Part number	: 018362887
Working voltage	: 19 to 28.8 VAC
Power consumption	: 10W (Max)
Display	: Monochrome graphics LCD (128 x 64)
Protections	: Power interruption & low voltage cutoff
Detection	: Zero crossing detection
Keypad	: 6keys

### Terminal connections

X01 - Power supply 24VAC, OV (Earth will be connected via socket)

X02 - Digital input (5), analog inputs (2), RS485 (MODBUS communication)

X03 - relay output (Main, Star, Delta)

X04 - Relay output (load/unload, programmable relay 2 no's)

X05 - Phase reverse / Phase loss detection

Relay outputs	: 6 Ports
Rated voltage	: 24VDC / 230VAC
Rated load	: 10A @ 230VAC
Contact resistance	: max 100milli ohms
Insulation resistance	: min 1000Meg ohms @ 500VDC
Usage	: 4 pre-programmed (main, star, delta, load / unload solenoid) 5Th & 6Th relay - : programmable for warn / ready / remote / trip / service / standby / load / FAN /ADV
Digital inputs	: 5 Ports
Rated voltage	: 24VDC
Usage	: Emergency stop, motor overload, cooler overload, remote load_ unload/spp, remote : start/stop
Analog inputs	: 2 Ports

### 1 x 4-20mA inputs for pressure

Range	: 0~16 bar (0 to 232 psi)
Resolution	: 0.1bar (1 psi)
Accuracy	: ±0.1bar (1 psi)

### 1 x Resistance input for temperature (PT1000)

Range	: -10~150°C (14 to 302°F)
Resolution	: 1°C (2°F)
Accuracy	: ±1°C (2°F)

### **3Phase detection**

Phase loss /phase reverse detection before starting the compressor

### **Communication ports**

Protocol	: MODBUS RTU protocol
Mounting	: 128 x 99 mm - Panel
Mounting overall dimensions :	: 172 x 123x 80 mm
Regulatory	: CE, UL
Operating temp	: -10 ~ 55°C (14°F ~ 122°F)
Storage temp	: -10 ~+70°C (14°F ~ 158°F)
IP protection	: IP55 on the front panel side
RH	: <95% @ 40°C (104 °F) without condensation

### 7.2.1. Equipment's safety

ELGi conduct thorough checks of the device before delivery according to the prescribed tests of the inspection scheme. In order to maintain this status through shipment and secure a safe operation, the user must consider the notes and warning notes provided as safety tips and in the instruction manual.

#### Important points to observe

The device must be operated by only trained persons. Maintenance and repair must be executed only by trained, technical staff, who are familiar with the associated dangers. The device can be operated without impairment of its security within the certified environment condition.

#### 7.2.1.1. Static discharge warning

This equipment is sensitive to electrostatic discharge, which can cause internal damage and affect normal operation. Follow these guidelines when you handle this equipment

Touch a grounded object to discharge potential static.

Wear an approved grounding wrist-strap.

Do not touch connectors or pins on component boards.

Do not touch circuit components inside the equipment.

Store the equipment in appropriate static-safe packaging when not in use.

#### 7.2.1.2. Assembly

The place of assembly must correspond to the class of protection. The ambient temperature at the place of installation should not exceed the recommended temperature for the nominal use, as specified in the data sheet. It is not to be used in wet conditions.

The devices may must be installed only outside of explosion hazardous areas.

#### 7.2.1.3. Electrical connection

External connections must be carried out according to rules in the respective country where the compressor is being used.

Switch off the device before carrying out any wiring work.

Do not connect or disconnect any wire when the device is operating.

#### 7.2.1.4. Power supply

Ensure that the supply voltage corresponds with the specification on the type sign.

Consider the load on the electrical circuit/phase before you switch on the device along with other devices and/or mechanisms. Do not connect welding or such high electrical noise sources to the same line as the controller supply.

### 7.2.2. General instruction

Observe the following procedures and instructions closely to avoid damage to the control panel and its associated equipment. Reliability of the system depends upon proper installation and maintenance.

The device is to be examined for damages resulting from

inappropriate feed and storage. If the device indicates damage that could impede safe operation, stop operating.

Carefully unpack the system. Open the door and inspect the cabinet, door, printed circuit board and other components for shipping-related damage.

Good practice is to store the cabinet in a clean, dry area until you mount it.

Return the signal cables and power cable separately.

Connect the protective earth in the panel to field earth only.

#### Protection from direct sunlight

Since the electronic circuits must not be subjected to uncontrolled temperatures, place the cabinet in the shade, away from direct sunlight.

#### Protection from rain

Partial tightening of the screws or doors would allow water to enter the enclosure and cause irreparable damage to the circuitry. Provide a canopy over the unit to prevent rainwater from entering the machine.

#### Do not install equipment on structures subject to continuous vibration

partially tightened wires or components in the cabinet disconnect during vibrations and cause irreparable damage to circuitry.

## 7.3 Display & terminal details

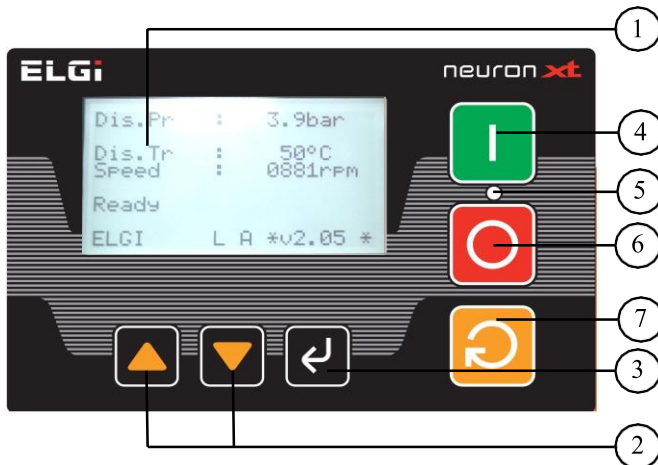

- 1 128x64 Graphical display
- 2 Navigation keys
- 3 Enter key
- 4 Start key
- 5 LED (Green - Start , Red - Stop/Fault )
- 6 Stop key
- 7 Reset key

### 7.3.1. Terminal connection

- X01 - Power supply 24VAC, 0V (Earth will be connected via socket)
- X02 - Digital input (5), Analog inputs (2), RS485 (MODBUS communication)
- X03 - Relay output (main, star, delta)
- X04 - Load/unload & Programming relay output (2)
- X05 - Phase reverse / Phase loss detection

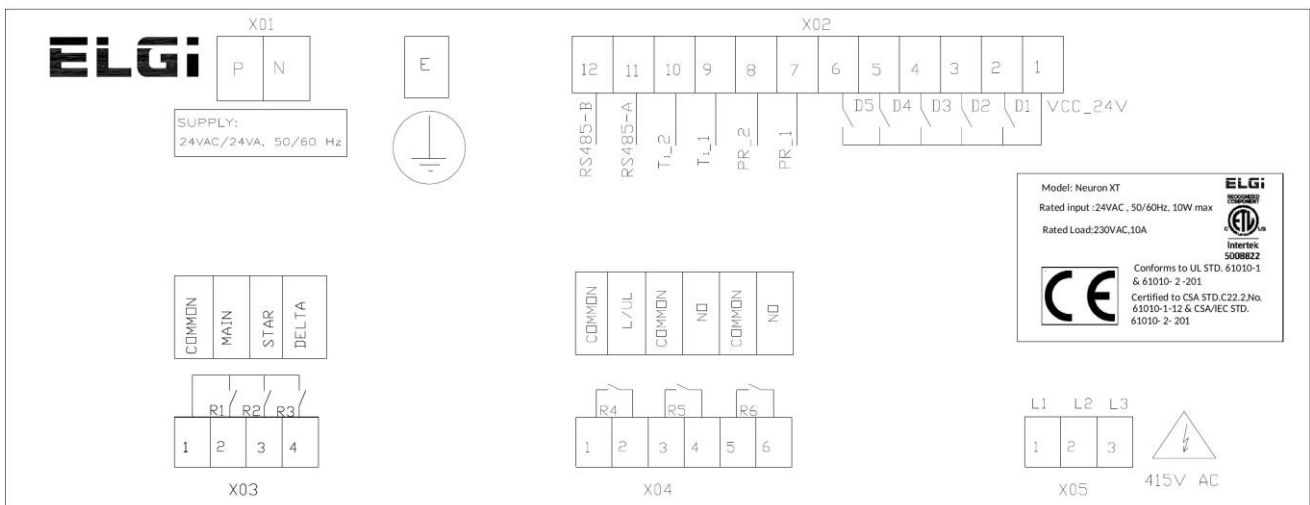

## 7.4 Neuron-XT salient features

### 7.4.1. Home screen display

- Easy User interface 8-line graphical display and intuitive menu navigation keys

### 7.4.2. Records (view -> fault report)

- 99 fault reports
- Faults with run hour and status of the machine at the time of fault etc.

### 7.4.3. Remote function (both from MODBUS as well as digital input)

- Remote loading and unloading
- Remote start and stop

### 7.4.4. Other interfaces and communication

- 70 + Modbus parameters for DCS controls

### 7.4.5. Safeguard

- Low voltage and short time power interrupts detection to enhance the life of the contactors
- Low temperature start inhibit to avoid start-up overloads



## 7.5 Input output description

### 7.5.1 X01: Power supply

Pin	Function	Id	Active state
1	24V AC Phase	P	-
2	24V AC Neutral	N	-

### 7.5.2 X02: Digital / Analog inputs & Communication

Pin	Function	Id	Active state
1	Digital inputs common	24VDC	-
2	Emergency stop	Emergency	Fault if open
3	Main motor Overload	MMOL	Fault if open
4	Cooler Motor overload	Cooler OL	Fault if open
5	Remote load and unload / spp	Remote L / UL / spp	Unload if open/ Trip if open
6	Remote start / stop	Remote Start /Stop	Stop if open

Pin	Function	Id	Type	Range
7	Discharge pressure—15~24V DC	Pr-1	4-20 mA	0 to 16 bar (0 to 232 psi)
8	Discharge pressure	Pr-2		

Pin	Function	Id	Type	Range
9	Discharge temperature	T1-1	PT1000	-10 to 150°C ( 14 to 302°F)
10	Discharge temperature	T1-2		
Pin	Function	Id	Type	Protocol/Range
11	DCS interface	RS485 -A	RS485	Modbus RTU protocol
12	DCS interface	RS485 -B	RS485	

### 7.5.3 X03: Relay output

Pin	Function	Id	Active state
1	Common for Main, Star and Delta	Common	-
2	Main Contactor	Main	Energise
3	Star Contactor	Star	De-Energise
4	Delta Contactor	Delta	Energise

### 7.5.4 X04 : Relay output

Pin	Function	Id	Active state
1	Common - Load relay	Common	Load when energised
2	Load relay	L/UL	
3	Common - programmable relay 1	Common	Energised
4	Programmable relay 1	No	
5	Common - programmable relay 1	Common	Energised
6	Programmable relay 2	No	

**7.5.5 X05: Single phase detector**

<b>Pin</b>	<b>Function</b>	<b>Active state</b>
1	R- Phase	R - 120 Deg Phase Diff
2	Y - Phase	Y - 120 Deg Phase Diff
3	B - Phase	B - 120 Deg Phase Diff

- Discharge pressure at 0.1bar / 1psi resolution
- Oil temperature at 1°C / 2°F resolution
- VFD speed (if VFD enabled)
- Trip or machine status like Run, Load, Unload, Standby etc.,
- Warning messages
- Version with mode information

### Compressor mode selection details:

1. UL - unload mode enabled, UL disabled the space will be shown as empty
2. L or R or D - compressor start from - Local or remote or DCS,

3. A or M - Auto restart enabled or auto restart disabled. For more details refer machine settings in operator menu.

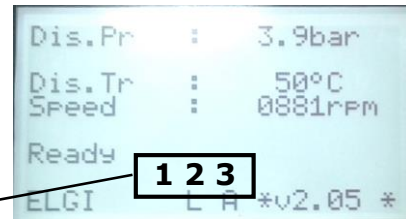

7.6.1

### Important machine settings for

#### NOTE

The version (eg. v2.04) displayed in main screen refers to software version (changes for every software update)

### Message 1 - Compressor status message

Status	Description
Ready	Ready for start
Star	Motor running in star
Run	Motor running in delta
Run load	Compressor in load
Run unload	Compressor in unload
Stop busy	Stop sequence in progress
Emergency stop	Emergency stop push switch is on
Temperature inhibit ±XX	While starting, if the discharge temperature is lower than the set inhibit temperature value, you will see this message. ±XX denotes the live discharge temperature value. The compressor starts only if the discharge temperature value goes above the set value.
Auto restart "seconds"	If compressor is in auto mode, The controller will ensure minimum delay (user set, e.g. 60 sec) between stop and start. count stops if "STOP" key is pressed
Start ack wait...	This message is displayed after a fault is cleared and waiting for user acknowledgement. By pressing "RESET" key user can acknowledge.
Standby	Compressor in standby mode.

### Message 2 - Compressor fault message

Fault	Description
Pr. Probe failure	Discharge pressure sensor probe failure
Tr. Probe failure	Temperature sensor probe failure
HSP	If discharge pressure exceeds the set high sump pressure value.
Cooler	If the cooler digital input opens due to cooler fault.
Main motor overload	If the MMOL digital input opens due to main motor
Phase loss/reverse	If input phase is lost or reversed before start of the main motor.
Trip temperature	If the discharge temperature exceeds the set trip temperature value.
Power interruption	If the mains supply is interrupted for more than 20 msec.
Low voltage	If the mains supply voltage is less than 75% of the rated voltage, the compressor will be tripped and all controller operations have halted until the mains supply comes back to normal (at least 85% of the rated).
Dis. pressure not developing	After the load, the discharge pressure should be at least 0.5 bar/7psi in 5mins. If it has not reached this level, this fault occurs.
Temperature not developing	If the discharge temperature not raised above the inhibit temperature before the set inhibit temperature time.

### Message 3 - Compressor warning message

Warning	Description
Warn temperature	When discharge temp. exceeds the set warn temperature (Default is 105°C)
Change oil filter	When service remaining Hr. reaches 0000
Change air filter	When service remaining Hr. reaches 0000
Change oil	When service remaining Hr. reaches 0000
Change grease	When service remaining Hr. reaches 0000
Change separator	When service remaining Hr. reaches 0000
Change valve kit	When service remaining Hr. reaches 0000

#### users

### 1. Control mode

**Local** - User can start and stop the compressor by using local start/stop key

**Remote** - User can start and stop the compressor by using potential free digital input. (refer digital input connector - X04).

**DCS** - User can start and stop the compressor by using RS485 MODBUS communication port ( refer connector - X02 ).

### 2. Unload mode

#### NOTE

*In the case of an emergency, good practice is to stop the compressor regardless of the control mode that the compressor is in. Use the "Emergency Stop Push Button" available on the front panel to stop the compressor.*

- If this is enabled, compressor operates only in unload mode and never in load mode. (This mode is used for service and maintenance purpose).

### 3. Auto restart

- If you enable this option, compressor will runs automatically after power failure and it resumes based on the previous condition. The default delay setting is 30 sec\*.

### 4. Warn RST delay

- Enable this option to delay the compressor start after power resumes. This option works if Auto Restart Mode is ON. (Default :30 sec)

### 5. Load / Unload pressure

- The compressor runs between load and unload pressure based on compressed air utilization. You can set your own load/unload pressure within the operating pressure band zone.

### 6. Star delay

- For Star to Delta change over delay time, the default delay setting is 6 sec.

### 7. DTR delay

- For Delta change over to load delay time, the default delay setting is 3 sec.

### 8. RTS delay

- During normal stoppage, the compressor will unload to before it stopped and wait for this set delay time. A default delay setting of 5 sec has been provided.

### 9. Standby time

- The compressor will shift to standby mode if unloading exceeds the specified time. A default delay setting of 5 mins has been provided.
- **Standby resume** - If the actual pressure is less than the load pressure, then the compressor will restart automatically after 10 sec delay. If demand from the standby stop comes after 10 sec, the compressor will start immediately. This feature helps save the energy if very little compressed air is used.

### 10. Start/Stop per hour

- The system sends a warning if you exceed the configured number of cycles per hour that you start the compressor per hour. The default factory setting is five per hour.

### 11. Load/Unload source

- **Local:** Load/ unload pressure is based on local settings.
- **Remote selection from the digital input-** Load/ unload is possible.

#### NOTE

*In case the compressor exceeds the specified number of cycles per hour when in the standby sequence, then the system will not enter into standby stop sequence until the existing hours are completed. In the mean time standby override will display on the screen.*

- **DCS:** Load/ unload can be operated from the DCS (The load/unload command should be used continuously with the interval  $\leq 3$  Sec)

### 12. VFD Function

- VFD speed will appear in the home screen once VFD mode is enabled in factory settings.

#### NOTE

• **VFD mechanism** - Load and unload pressure which set in  
*The compressor resumes in local load and unload mode if communication is lost in DCS mode.*

operator will write into VFD's respective address through Modbus protocol

**NOTE**

*Modbus communication should be established between VFD and Neuron -XT controller. If VFD is enabled other slave device should not be connected, such as DCS.*

## 7.7 Menu structure

Press any one of the following keys  $\Delta$  and  $\nabla$  to enter main menu

### 7.7.1 Main Menu

Dis. Pr	: 0.0 bar / 0 psi
Dis. Tr	: 25°C / 77°F
Status	:
	View
	Operator
	Service
	Factory
	Customer care

LEVEL 1	LEVEL 2	LEVEL 3	LEVEL 4	
View	Operator	Mode	Control mode	Local / Remote / DCS
			Auto restart	On/ Off
			Pressure unit	Bar/psi
			Temperature unit	Fahren / Centi
		Pressure	Unload pressure	X X . X b or p (bar or psi)
			Load pressure	X X . X b or p
		Delay	Warn RST delay	X X X s (second)
			Star delay	X X s
			DTR delay	X X s
			RTS delay	X X s
			Standby time	X X m (minute)
			St/Sp PH	X X
		DCS port	Type	Modbus
			ID	X X
			Baud	9600/19200
			Parity	None / Even / Add
			Length	8 / 7
			Stop bit	2 / 1
		Temperature	Trip temperature	X X X C or F
			Warn temp	X X X C or F
			Fan temp	X X X C or F
		Rating	XXXXXXXXXX	
		Fab No.	XXXXXXXXXX	

### 7.7.1.2 Fault Report

Use  $\Delta$  and  $\nabla$  to select the fault record number (1 to 99). The latest fault will be displayed in the first position. For fault message details refer the "Fault Message" table.

LEVEL 1	LEVEL 2	LEVEL 3
View	Fault report	Fault Message
		Run Hour : XXXXXX
		Dis.Pr : X X .X
		Dis.Tr : X X X
		Status : RDY/ACK/STAR etc.,

### 7.7.1.1 Operator

### 7.7.1.3 View Service Time

LEVEL 1	LEVEL 2	LEVEL 3
View	Service time	Remaining AFCT: X X X X X hours
		Remaining OFCT: X X X X X hours
		Remaining OSCT: X X X X X hours
		Remaining OCT: X X X X X hours
		Remaining RGT: X X X X X hours
		Remaining Valve kit: X X X X X hours

### 7.7.1.4 View Cumulative Time

LEVEL 1	LEVEL 2	LEVEL 3
View	Cumulative time	Load X X X X X hrs: X X Min
		Unload X X X X X hrs: X X Min
		Run X X X X X hrs: X X Min
		Stop X X X X X hrs: X X Min
		Fault X X X X X hrs: X X Min
		Standby X X X X X hrs: X X Min
		Start Count X X X X X
		Load Count X X X X X X X X
		Utilisation X X %

## 7.7.2 Operator

Password required to adjust the operator settings within the set limits.

### 7.7.2.1 Operator Machine

Operator	Machine
	Maintenance
	Language
	Change Password

The machine settings available are listed in the below table.

#	Item	Min	Max	Option	Default	Unit
<b>Mode</b>						
1	Control mode	-	-	loc/rem/dcs	loc	-
2	Auto restart	-	-	on / off	off	-
3	Pr unit	-	-	bar / psi	bar/psi	-
4	Tr unit	-	-	cen / for	cen	-
<b>Pressure</b>						
5	Unload pressure	$\geq$ load pressure +0.5bar(7psi)	$\leq$ max unload pressure	-	7.5 bar (109 psi)	bar/psi
6	Load pressure	4.0bar(58psi)	$\leq$ unload pressure - 0.5bar(7psi)	-	5.5 bar (80 psi)	bar/psi

#	Item	Min	Max	Option	Default	Unit
<b>Set Delay</b>						
8	Warn RST	30	250	-	30	second
9	Star	6	20	-	6	second
10	DTR	3	60	-	3	second
11	RTS	5	30	-	5	second
12	Standby	3	99	-	5	minute
<b>DCS Port</b>						
13	Type	-	-	Modbus	-	
14	ID	1	99	-	1	-
15	Baud	-	-	9600/19200	9600	bps
16	Parity	-	-	None/Even/Odd	None	
17	Length	-	-	7 / 8	8	-
18	Stop bit	-	-	1 / 2	1	-
<b>*Auto Drain Valve (ADV)</b>						
19	Off time	1	180	-	4	minute
20	On time	1	15	-	5	Second
<b>Load / Unload Source</b>						
21	LD / UL Source	-	-	Loc / Rem/ DCS	Loc	-
<b>Contrast adjust</b>						
22	Contrast adjust	10	100	10 / 100	50	%

\* If ADV enabled in service menu

### 7.7.2.2 Operator - Maintenance

If you change the below consumables, then select Yes to restart the service counter from the default set value.

#	Item	Min	Max	Option	Default	Unit
1	AF changed	-	-	No/Yes	No	-
2	OF changed	-	-	No/Yes	No	-
3	OS changed	-	-	No/Yes	No	-
4	Oil changed	-	-	No/Yes	No	-
5	Re-grease	-	-	No/Yes	No	-
6	Valve kit	-	-	No/Yes	No	-

### 7.7.2.3 Language

Default is english. Customer can choose any one of the given languages.

#	Item
1	English
2	Francais
3	Italiano
4	Spanish



### 7.7.3 Service

Password required.

#### NOTE

Any setting changes should be made by an ELGi authorized service engineer only. Any attempt to change service settings by unauthorized people may lead to compressor malfunction and the warranty becoming void.

Service Calibration (Offset)
Relay
Temperature
Maintenance
Self-Test
Change Password
Unload Mode
DI-5

#### 7.7.3.1 Calibration (offset)

If any deviation occurs in the pressure and temperature displayed between the controller and the master gauge, ask ELGi service engineer to offset the valve. Factory fitted sensor/controller are pre-calibrated.

#### 7.7.3.2 Programmable relay

Select the programmable relay 1 or 2 using the Δ and ▽ keys. Then press Enter to assign any one of the following functionalities for the relay.

##### Default

#	Item
1	Warn
2	Load
3	Service
4	Standby
5	Trip
6	Remote
7	Ready
8	Fan*
9	ADV* *

Relay 1 = Warn  
Relay 2 = Trip

#### 7.7.3.3 Temperature

- Fan temperature\*** - (If a fan is equipped with machine) This option causes the fan relay to energize always on.
- Inhibit temperature** - This option causes the compressor to start when the discharge temperature is higher than the set value (if Temperature inhibit is enabled in factory settings).
- Temperature Inhibit time** - - This option causes the compressor to wait for this specified time to reach the Inhibit temperature.

If not, it trips because temperature is not building.

#### 7.7.3.4 Auto drain valve\*\*

The auto drain valve is a special feature that helps prevent

water from entering into compressed air delivery. This function enables the drain valve to switch on and off based

#	Item	Min	Max	Option	Default	Unit
1	Fan Temp	60°C (140°F)	90°C (194°F)	-	85°C (140°F)	C/F
2	Inhibit Temp	- 5°C (23°F)	5°C (41°F)	-	0°C (32°F)	C/F
3	Tr. Inhibit Time	5	90	-	5	min

on a specified time in the menu. The default setting is 5 sec ON with a 4 min interval. It is programmed in the relay menu available in service.

#### 7.7.3.5 Maintenance

Here you can feed the filter life time. The time limit will vary depending on the model and filter. Contact your authorized dealer to learn more.

Good practice is to record the details in the operator/ maintenance menu once the filter is replaced.

#### 7.7.3.6 Self test

Perform a self test to verify the controller display, mimic LEDs, keys, analog and digital inputs/outputs. Follow the instructions that appear in the screen.

#### 7.7.3.7 Unload mode

#	Item	Min	Max	Option	Default	Unit
1	Set AFCT	0000	30000	-	2000H	Hour
2	Set OFCT	0000	30000	-	2000H	Hour
3	Set OSCT	0000	30000	-	4000H	Hour
4	Set OCT	0000	30000	-	2000H	Hour
5	Set RGT	0000	30000	-	2000H	Hour
6	Set Valve Kit	0000	30000	-	2000H	Hour

If you enable this option, the compressor will run only in the unload mode. The option disables compressor load mode. (This mode is used for service and maintenance purpose).

#### WARNING

Conduct self test only after you totally disconnect compressor wiring from the controller. Else, the compressor will sustain severe damage. A self-test must be done only by an authorized service person.

#### 7.7.3.8 Digital Input

This input can be configured as either the Remote Load/ Unload or spp function. Default: Remote Load/Unload

#### 7.7.4 Customer care

If customer enter into the customer care menu, this message will appear

\* Version may vary based on the software update.

## 7.8 Data interface

DCS port is Modbus RTU type. It enables you to interface with the generic DCS.

You can set the device ID in menu "Operator/ Machine/ DCS Port."

You can also configure the baud rate, parity, data length,

Version: XXXX*
URL: <a href="http://www.elgi.com">www.elgi.com</a>
E-mail: <a href="mailto:ccs@elgi.com">ccs@elgi.com</a>

and the stop bit to suit your requirements. The Modbus table will be provided on request.

## 7.9 Troubleshooting

S. NO	Failure symptoms	Possible causes	Remedies
1	No display in LCD Screen & Backlight was not glown	No input supply	Check incoming supply to compressor
		Transformer failure	Please check the controller input voltage at connector X01. Voltage should be 24V ± 15% VAC.
		Controller failure.	Change the controller.
2	Keypad in Controller not responding	Key not responding	Check any key stuck / Flat. If any change Controller
		Key struck / Flat	Change the controller.
3	"Low voltage" message in display.	Controller Input voltage less than 18VAC	Until will start functioning, once input voltage recovered to nominal or with in specification ( 415 V +10% - 15 %)
4	"Pr. probe failure" message in display	Loose connection in connector position (X02 - 7 & 8).	Check the loose connection at both end - Controller and pressure sensor side.
		Pressure sensor failure.	Change the Pressure sensor.
		Controller failure	Check the voltage across (X02 - 8) with Gnd, voltage should be b/w 0.4 to 2VDC. If it is different change the controller.
5	"Tr. probe failure" message in display	Loose connection in connector position X02 - 9 & 10.	Check the loose connection at both end - Controller and Temp sensor side.
		Temperature sensor failure.	Change the Temperature sensor.
		Controller failure	Check the voltage across X02 - 9 with Gnd, voltage should be 3.3 VDC. If it is different change the controller.
6	"Emergency stop" "MMOL" "Cooler OL" message in display	Loose connection in connector position (X02 - 1, 2 ,3 & 4).	Check the loose connection at controller end.
		Switch got struck	Check either the external switches got sturck / Fault not cleared
		Controller Failure	Change the controller.
7	Motor not driving	Controller failure	Disconnect the X03 & X04 connector, Check the relay working by switching on the start key (X03 -1) with (X03- 2, 3 & 4) & (X04 -1) with (X04- 2). Note: Ckeck in the continuity mode.
8	"Phase loss/ Reverse" message in display	Loose connection in connector position (X05 - 1, 2 & 3).	Check the loose connection at controller end.
		Controller failure	Check for the X05 connection X05(1- R, 2-Y, 3 -B), Still the same error change the controller

## 7.10 Construction

- Plastic enclosures
- IP65 polyethylene front keypad
- Inputs and outputs through terminal block
- Front plate cutout dimensions 154 x 105 mm
- Enclosure dim

### 7.10.1 Dimension drawing

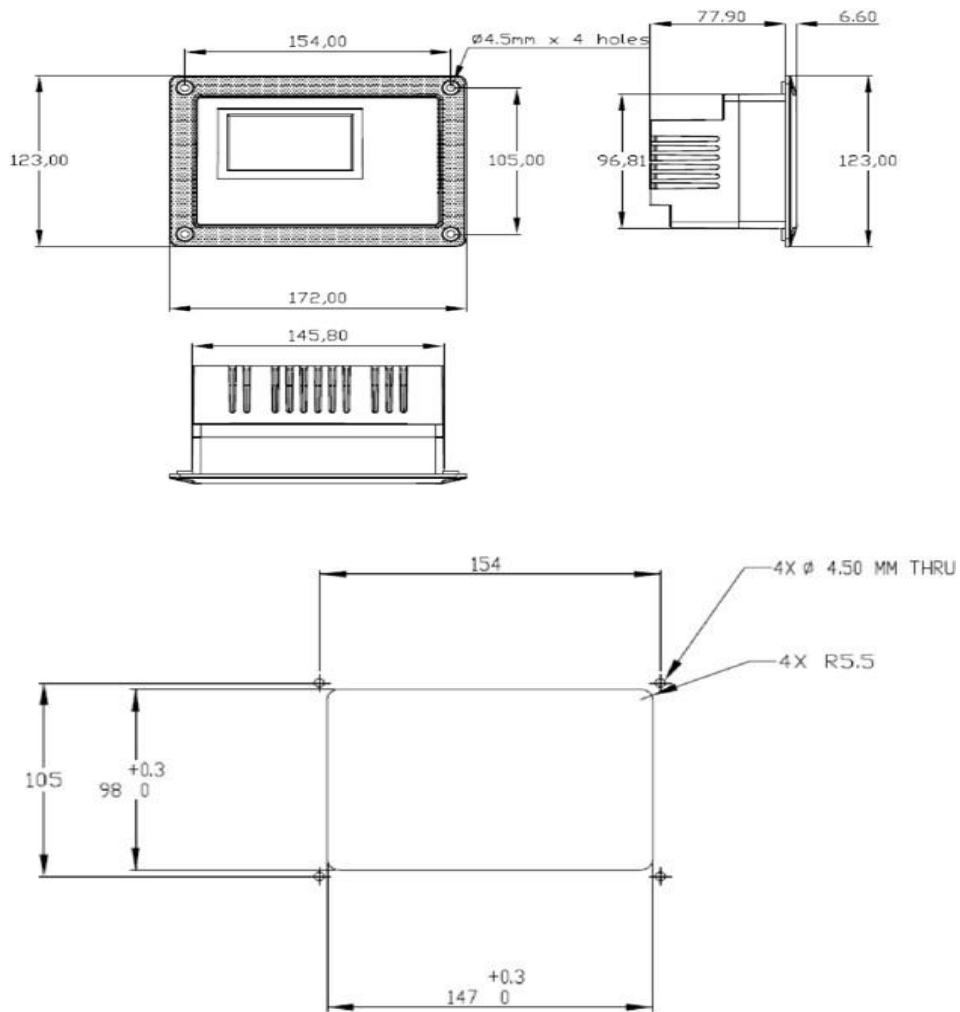

### PANEL CUTOUT DIMENSION

## 7.11 Neuron XT quick reference

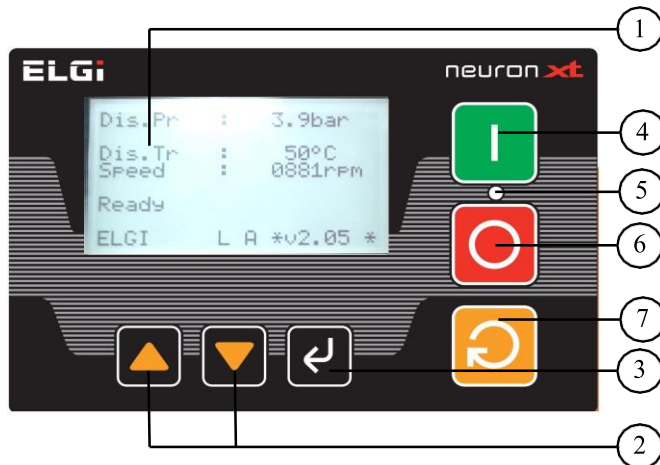

- 1 128x64 Graphical display
- 2 Navigation keys
- 3 Enter key
- 4 Start key
- 5 LED (Green - Start , Red - Stop/Fault )
- 6 Stop key
- 7 Reset key

### MAIN SCREEN DISPLAY

- Package Discharge Pressure
- Discharge Temperature
- Machine Status like Run, Load, Unload, Standby etc.
- Warning Messages
- Mode Information (see below)

#### Mode Information

1. PS – Pressure Schedule Enabled / UL – Unload Mode Enabled
2. L – Local / R – Remote / D – DCS
3. A / M – Auto Restart ON / Manual Mode

#### Compressor Status messages

Status	Description
Ready	Ready for start
Star	Motor running in star
Run	Motor running in delta
Run load	Compressor in load
Run unload	Compressor in unload
Stop busy	Stop sequence in progress
Emergency stop	Emergency stop push switch is on
Temperature inhibit ±XX	While starting, if the discharge temperature is lower than the set inhibit temperature value, you will see this message. ±XX denotes the live discharge temperature value. The compressor starts only if the discharge temperature value goes above the set value.
Auto restart "seconds"	If compressor is in auto mode, The controller will ensure minimum delay (user set, e.g. 60 sec) between stop and start. count stops if "STOP" key is pressed
Start ack wait...	This message is displayed after a fault is cleared and waiting for user acknowledgement. By pressing "RESET" key user can acknowledge.
Standby	Compressor in standby mode.

### Compressor Warning messages

Warning	Description
Warn temperature	When discharge temp. exceeds the set warn temperature (Default is 105°C)
Change oil filter	When service remaining Hr. reaches 0000
Change air filter	When service remaining Hr. reaches 0000
Change oil	When service remaining Hr. reaches 0000
Change grease	When service remaining Hr. reaches 0000
Change separator	When service remaining Hr. reaches 0000
Change valve kit	When service remaining Hr. reaches 0000

### Compressor fault messages

Fault	Description
Pr. Probe failure	Discharge pressure sensor probe failure
Tr. Probe failure	Temperature sensor probe failure
HSP	If discharge pressure exceeds the set high sump pressure value.
Cooler	If the cooler digital input opens due to cooler fault.
Main motor overload	If the MMOL digital input opens due to main motor
Phase loss/reverse	If input phase is lost or reversed before start of the main motor.
Trip temperature	If the discharge temperature exceeds the set trip temperature value.
Power interruption	If the mains supply is interrupted for more than 20 msec.
Low voltage	If the mains supply voltage is less than 67% of the rated voltage, the compressor will be tripped and all controller operations have halted until the mains supply comes back to normal (at least 75% of the rated).
Dis. pressure not developing	After the load, the discharge pressure should be at least 0.5 bar/7psi in 5mins. If it has not reached this level, this fault occurs.

**Menu Structure**

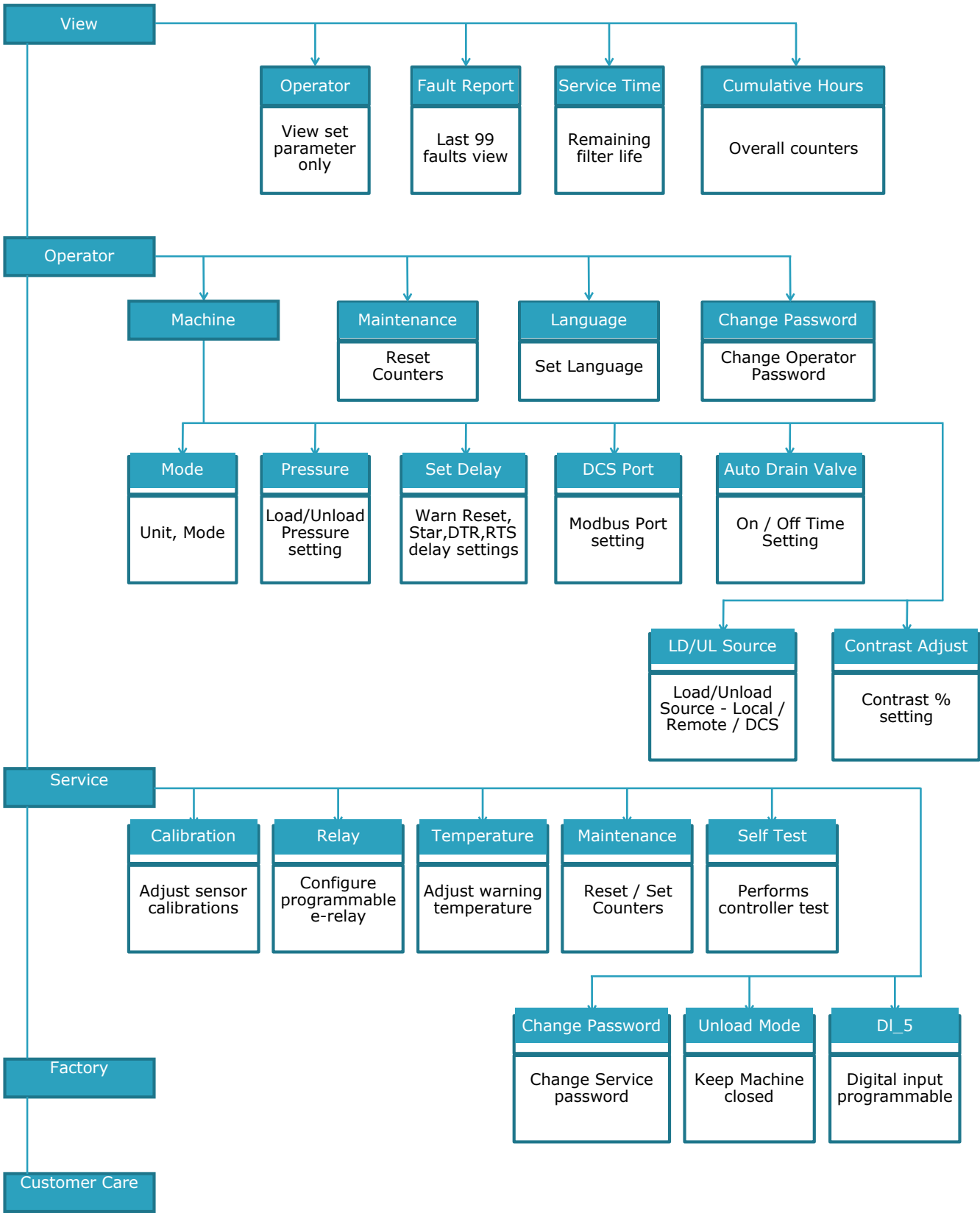

## 7.12. Revision Details:

<b>Version</b>	<b>Date</b>	<b>Changes</b>
1.0	02/03/2015	Initial Draft
2.0	31/08/2017	Updated corrections
3.0	02/01/2018	Feature addition/deletion
3.1	01/08/2018	Software version 1.8
3.2	01/12/2018	Software version 2.04
3.3	28/03/2019	Software version 2.05
3.4	08/08/2019	Software version 2.06
3.5	22/10/2020	Software version 2.07a
3.6	20/12/2021	Correction on Pin numbering & Software version 2.07b





# **PARTS MANUAL**

## **EN SERIES**

ELECTRIC POWERED SCREW AIR COMPRESSOR  
EN 2 to EN 5

**8.0 Drive system**

[ Ref : 015324636—X019755] EN 5 - 9.5 bar.g

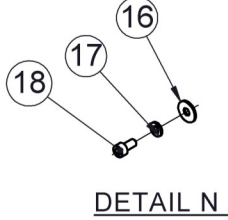
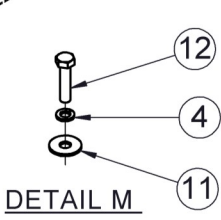
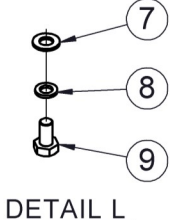
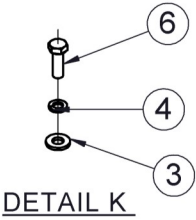
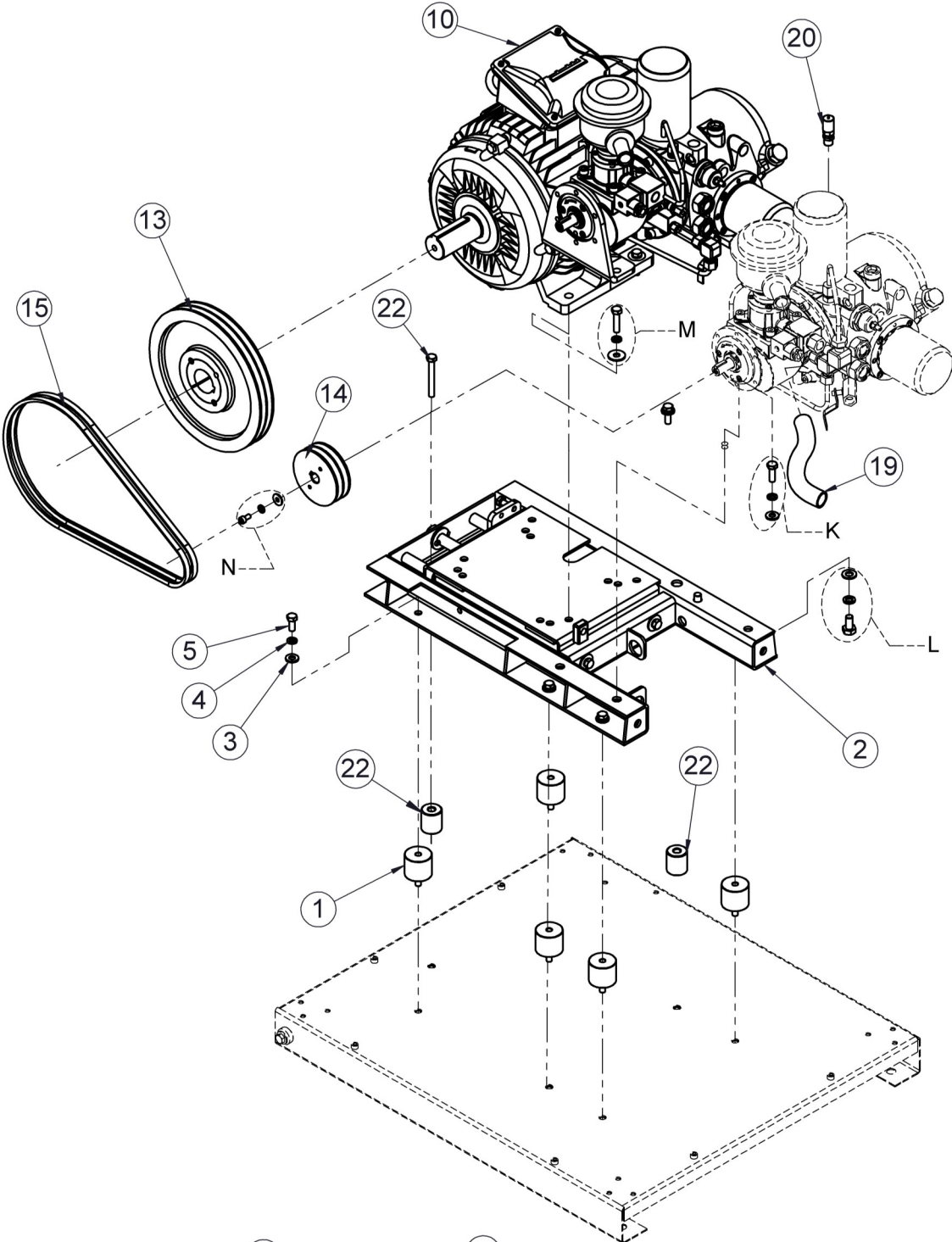

## 8.0 Drive system

[ Ref : 015324636—X019755]

Sl. No.	Description	Qty.	Part Number
1	AVM	5	B01406190005
2	STRUCTURE ASSEMBLY	1	015310813
3	PUNCHED WASHER M8	9	000996058
4	SPRING WASHER M8	13	000996108
5	HEX BOLT M8X20	5	000906115
6	HEX BOLT M8X25	2	000906116
7	PUNCHED WASHER M10	2	000996059
8	SPRING WASHER M10	2	000996110
9	HEX BOLT M10X20	2	000906143
10	MOTOR	1	B005300950017
11	PLAIN WASHER M8	4	000996008
12	HEX BOLT M8X35	4	000906118
13	DRIVE PULLEY	1	015313901
14	DRIVEN PULLEY	1	015303606
15	BELT	1	B014606410036
16	PLAIN WASHER M6	1	000996006
17	SPRING WASHER M6	1	000996106
18	HEX SOC SCREW M6X12	1	000983060
19	RUBBER CONNECTOR	1	015320692
20	SAFETY VALVE	1	B012806280008
21	HEX BOLT M8 x 60	2	000906123
22	AVM HOLDING BUSH	2	015403259

9.0 Cooling system

[ Ref : 015313602—X016004 ] EN 2 - EN 5

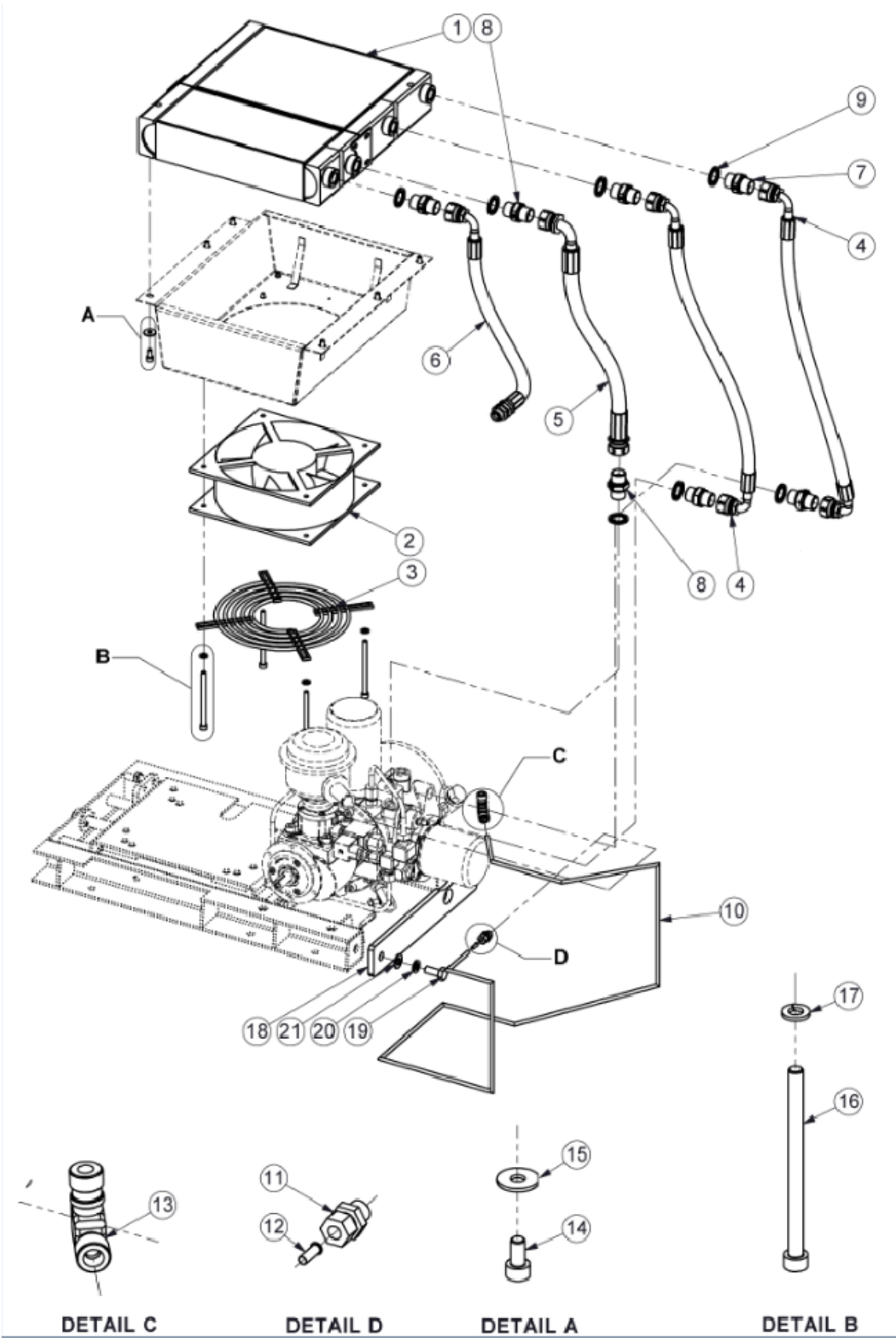

## 9.0 Cooling system

[ Ref : 015313602—X016004 ]

Sl. No.	Description	Qty.	Part Number
1	OIL & AFTER COOLER	1	B012905490002
2	AXIAL FAN	1	B005100950131
3	FANGUARD	1	018362844
4	HOSE-COOLER TO AE EN-5	2	015313379
5	HOSE-MPV TO COOLER IN EN-5	1	015313380
6	HOSE-AIR OUTLET EN-5	1	015313381
7	3-8 M-M HOSE CONNECTOR	5	015401693
8	3-8 TO 1-2 M-M HOSE	2	015401940
9	3/8 BSP BONDED SEAL	7	000959386
10	TUBING 6mm	1.0m	000920620
11	ST 1-8 TO 6mm OD	1	B010505390020
13	ELBOW ¼" BSPP X 6MM WITH	1	B009605390010
14	SCR SOC HD M6x12	6	000983060
15	WASHER PLAIN M6	6	000996006
16	SCREW HEX SKT HD CAP	4	000983058
17	WASHER PUNCHED M5	4	000996056
18	JOINING PLATE	1	015403924
19	HEX BOLT M10 X 25	4	000906144
20	WASHER PUNCHED M10	4	000996059
21	WASHER SPRING M10	4	000996110

**10.0 Base and canopy system**

[ Ref : 015313601—X016003 ] EN 2 - EN 5

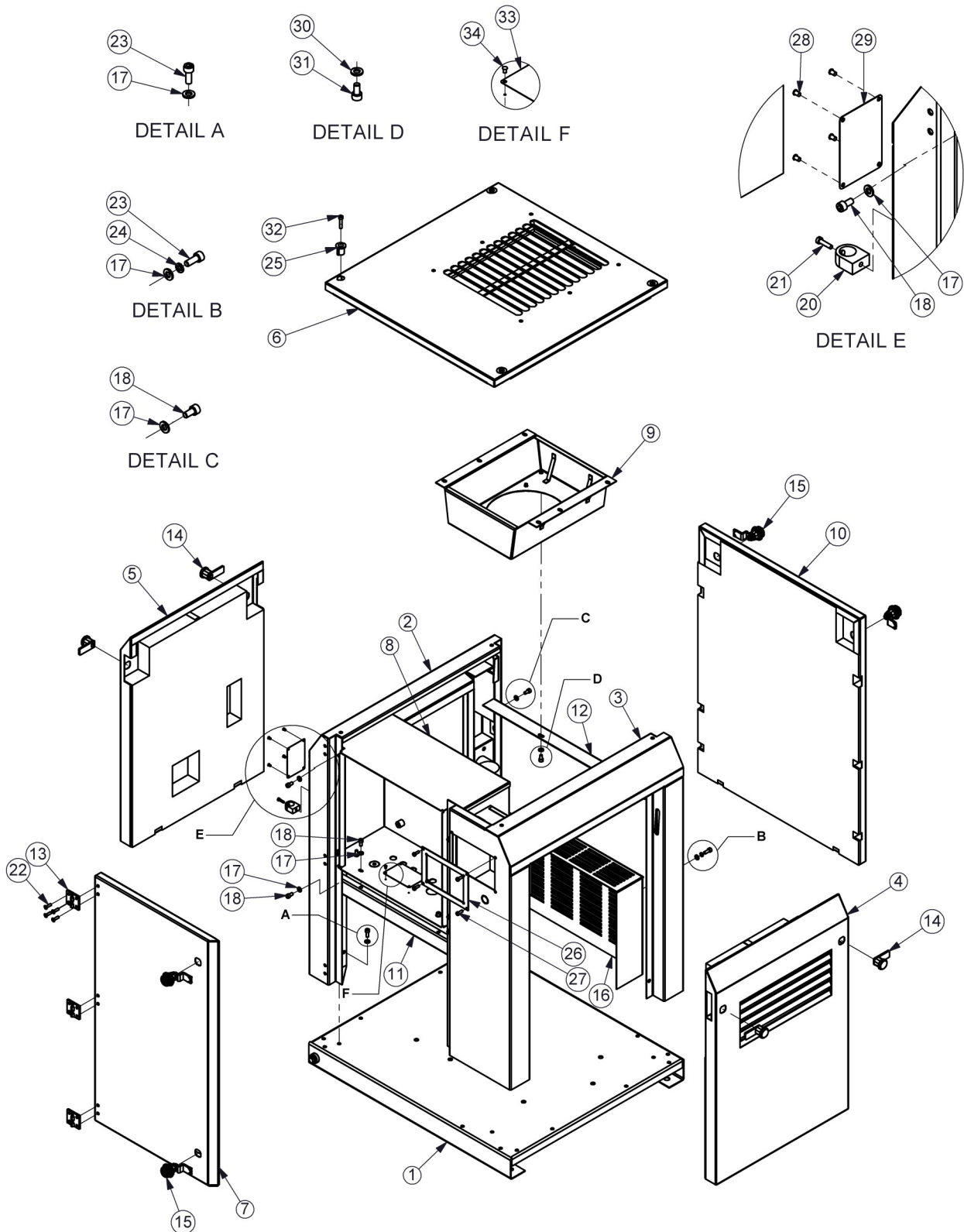

## 10.0 Base and canopy system

[ Ref : 015313601—X016003 ]

Sl. No.	Description	Qty.	Part Number
1	BASE ASSEMBLY EN-5/50HZ	1	015313367
2	PILLAR ASSY - SERVICE EN-5	1	015313362
3	PILLAR ASSY - MOTOR EN-5	1	015313363
4	MOTOR SIDE PANEL ASSY EN-5	1	015313375
5	AIREND SIDE PANEL ASSY-EN-5	1	015313922
6	TOP PANEL EN-5	1	015313374
7	DOOR ASSY CONTROL PANEL EN-5	1	015313376
8	CONTROL PANEL BOX EN-5	1	015313372
9	SHROUD ASSY EN-5	1	015313382
10	PANEL REAR EN-5	1	015313373
11	SUPPORT BAR EN-5	1	015313369
12	COOLER MTG BRACKET EN-5	1	015313371
13	HINGE	3	B015104790003
14	PA LOCK DPCL-18-SQ8-MR-F	4	B15204790010
15	PA LOCK DPCL-18-SQ8-MR27-F	4	B15204790011
16	BELT GUARD	1	015313377
17	PUNCHED WASHER M6	27	000996057
18	HEX SOCKET HEAD SCREW M6x12	6	000983060
19	KEY (NOT SHOWN IN DRAWING VIEW)	1	B15204790004
20	KEY HOLDER	1	015403237
21	SLOTTED HEAD SCREW M4x16	1	000983026
22	HEX SOCKET CSK SCREW M5x16	12	000976044
23	HEX SOCKET HEAD SCREW M6x16	17	000983062
24	SPRING WASHER M6	4	000996106
25	INSERT TOP PANEL EN-5	4	015403788
26	P1 ADAPTOR PLATE	1	015313900
27	SCR CH M4X20	4	000983487
28	POP RIVET ALU Ø3x14	4	000910002
29	NAME PLATE	1	01531088E
30	PLAIN WASHER M5	4	000996005
31	HEX SOCKET HEAD SCREW M5x12	4	000983042
32	HEX SOCKET HEAD SCREW M6x30	4	000983066
33	ENCLOSURE NAME PLATE-US PACKAGE	1	018361950
34	RIVET DIA2.5X6.5 NAME PLATE	4	000519530
35	PLAIN WASHER M6	4	000996006
36	HEX BOLT M6X20	4	000906086

**11.0 Airend system**

[ Ref : 990316160 - X990825 ]

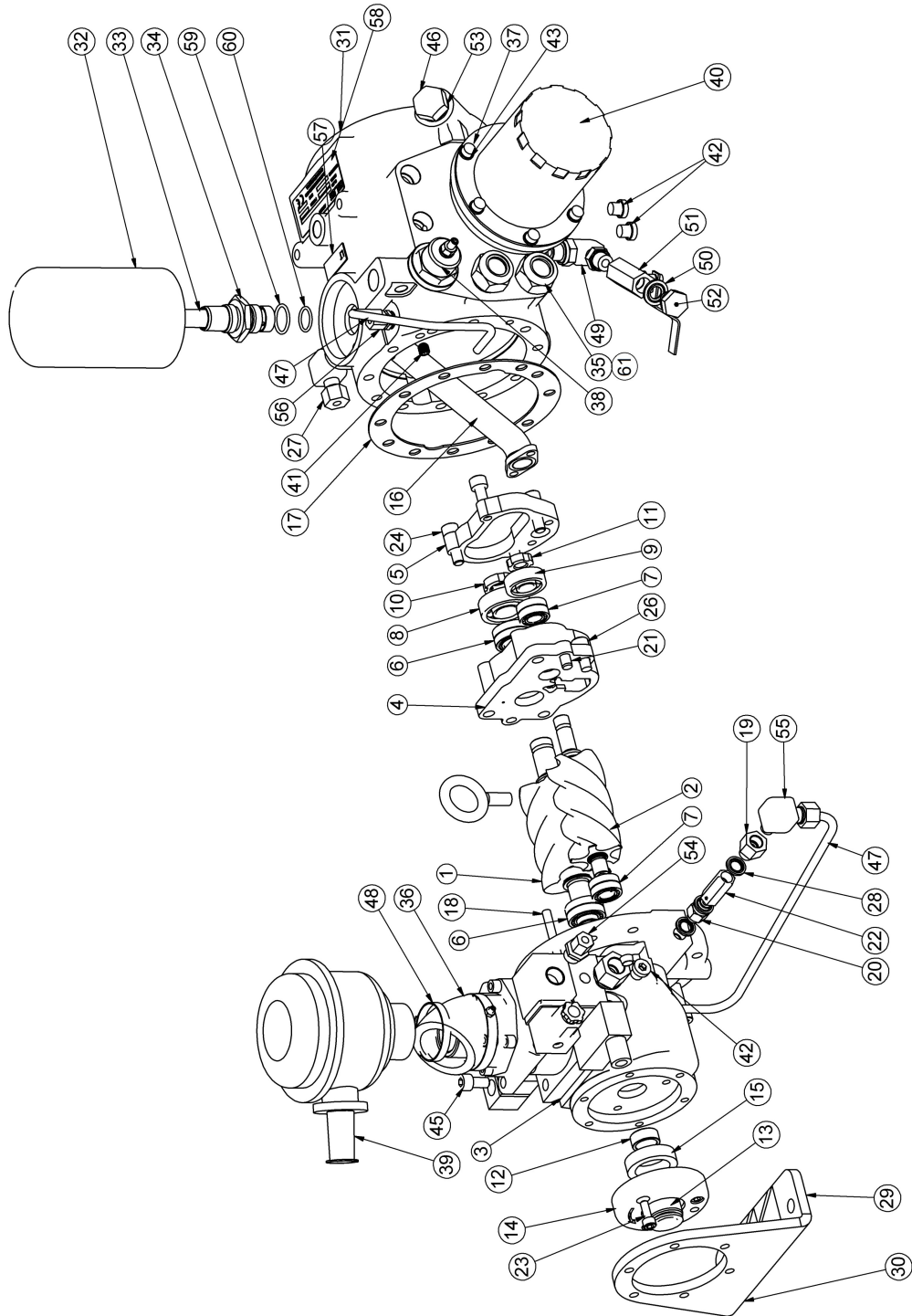



## 11.0 Airend system

[ Ref : 990316160 - X990825 ]

Sl. No.	Description	Qty.	Part Number	Sl. No.	Description	Qty.	Part Number
1	MALE ROTOR AXIS 53 ENCAP	1	990302450	37	THERMAL VALVE ASSEMBLY	1	A990797
2	FEMALE ROTOR AXIS53	1	990302460	38	MPV ASSY	1	A990080
3	ROTOR HOUSING	1	990302480	39	CLOSED AIR FILTER	1	B004705760004
4	BEARING HOUSING	1	990302500	40	OIL FILTER ASSY	1	X018282
5	BRG HSG COVER	1	990400820	41	HEX.SOC.GRUB SCREW M8X8	1	000987740
6	BRG NEEDLE ROLLER NA4903	2	000903911	42	CLOSURE PLUG G1/8	3	B010506360009
7	BEARING NEEDLE ROLLER	2	000903912	43	HEX.SOC.HEAD SCREW M6X12	4	000983060
8	BRG ANG CONTACT 7203 BE	1	000903402	44	HEX.SOC.HEAD SCREW M8X25	11	000983084
9	BRG ANG CONTACT 7201 BE	1	000903400	45	HEX.SOC.HEAD SCREW M8X16	4	000983081
10	LOCKNUT - MALE	1	013436861	46	OIL FILL CAP G3/8	1	990401950
11	LOCKNUT - FEMALE	1	013436862	47	TUBE SET, EN 53	1	990304260
12	SPACER,ENCAP (17X22X9)	1	990400750	48	SS WORM CLAMP JW6C,12.7,29 -45	1	B005000530015
13	SLEEVE WEAR AXIS 53	1	013436865	49	ELBOW G-1/4	1	B010506780014
14	SEAL HSG M/C, AXIS 53	1	013436859	50	1/4 BSP BONDED SEAL	1	000959384
15	SEAL SHAFT 28X40X10	1	013436029	51	BALL VALVE G1/4"	1	B313801
16	DISCHARGE PIPE (ENCAP)	1	990400830	52	PLUG;HEX.SOCKET HEAD	1	000427010
17	GASKET TANK-ROTOR HSG (AXIS 53)	1	990401610	53	3/8 BSP BONDED SEAL WASHER	1	000959386
18	KEY METRIC 5X5X20	1	990400110	54	G1/4X6MM TUBE MALE STUD COUPLING	1	B010501230001
19	CONNECTOR, G1/8 - 1/8 NPT	1	990402010	55	ELBOW TMS 1/4X1/8" NPT	1	22047681A
20	ORIFICE DIA 0.8, G1/8, M-M	1	990401530	56	BRASS MALE STUD CONN 1/4 X 6	1	B010505390001
21	PIN DOWEL 8D X20L	3	990400790	57	NAME PLATE , LEAK TEST	1	990402070
22	NON RETURN VALVE 1/8 INCH	1	B004100170001	58	NAME PLATE,CE	1	990403100
23	HEX.SOC.HD.SCREW M6X16	3	000983062	59	O-RING ID 19.3X2.2	1	990404650
24	HEX.SOC.HD.SCREW M6X25	4	000983065	60	O-RING ID 16X2	1	990404660
25	HEX.SOC.HD.SCREW M6X30	2	000983066	61	RUBBER RING, EN53	2	990406050
26	HEX.SOC.HD.SCREW M8X20	4	000983083				
27	ELBOW TMS 1/4X1/8 INCH	1	22047681A				
28	1/8 BSP BONDED SEAL	3	000959381				
29	AIREND MOUNTING BRACKET	1	015403776				
30	HEX.SOC.HD.SCREW M6X20	6	000983064				
31	TANK ,LEAK TEST	1	990404690				
32	AIR OIL SEPARATOR	1	B006700770017				
33	SEPARATOR TUBE	1	990404820				
34	DOUBLE FITTING	1	990404810				
35	OIL SIGHT GLASS G1/2	2	B004606280001				
36	INTAKE VALVE	1	B009800780010				

## Kit details

### Insurance kit details: 012488179

S. No	Description	Part Number	Qty.
1	Temperature sensor	018400079	1
2	Pressure transmitter	00897902N	1
3	Thermal Valve assy.	A990797	1
4	MPV assy Kit	A990080	1
5	Intake Valve kit	B015400780001	1
6	Oil Sight Glass G1/2	B004606280001	1
7	Fittings kit	012476279	1
8	Shaft seal	013436029	1
9	Wear sleeve	013436865	1
10	Inner ring	990400750	1
11	Solenoid valve	B009800780015	1

### Belt Spare Part No.

S. No	Description	Part Number	Qty.
1	EN 2-125,150;EN3-150; EN 5-175 208-230/460 60HZ 3PH	B014606410086	1
2	EN 3-125 208-230/460 60HZ 3PH	B014606410077	1
3	EN 4-100, EN4-125; EN5-150 208-230/460 60HZ 3PH	B014606410062	1
4	EN 4-150,175 208-230/460 60HZ 3PH	B014606410063	1
5	EN 5-100 208-230/460 60HZ 3PH	B014606410036	1
6	EN 5-125 208-230/460 60HZ 3PH	B014606410051	1

## Consumables kit details

### 4000 Hours Service kit - 012488189

S. No	Description	Part Number	Qty.
1	Air Filter Element	B005705760001	1
2	Oil Filter Element 25lpm FW	X018283	1
3	Air Oil Separator	B006700770017	1

### 8000 Hours Service kit - 012488199

S. No	Description	Part Number	Qty.
1	Air Filter Element	B005705760001	1
2	Oil Filter Element 25lpm FW	X018283	1
3	Air Oil Separator	B006700770017	1
4	Intake Valve kit	B015400780001	1
5	MPV KIT	A990288	1
6	Thermal valve kit	A990287	1
7	O ring kit	012476289	1
8	Nylon tube	000920620	1
9	Solenoid valve	B009800780015	1

### Fittings kit - 012476279

S. No	Description	Part Number	Qty.
1	Connector 1/8	990402010	1
2	Connector 1/4	990402020	1
3	Tube set	990304260	1
4	Elbow 1-4 M-F	015401695	1
5	Hex nipple 1-4 M-M	015401696	1
6	TMS Elbow 1/4	22047681B	1
7	TMS Elbow 1/8	22047681A	2
8	TMS Coupling 1/4	22047683A	1

### O ring O ring Kit - 012476289

S. No	Description	Part Number	Qty.
1	Gasket	990401610	1
2	3/8 BSP Bonded seal washer	000959386	1
3	1/8 BSP Bonded seal washer	000959381	3
4	1/4 BSP Bonded seal washer	000959385	1

S. No	Description	Part Number	Qty.
1	AIREND ASSEMBLY WITHOUT TANK	A990273	1

### Hose Kit - 012487769

S. No	Description	Part Number	Qty.
1	Hose AE to cooler	015313379	1
2	Hose MPV to cooler	015313380	1
3	Hose air outlet	015313381	1

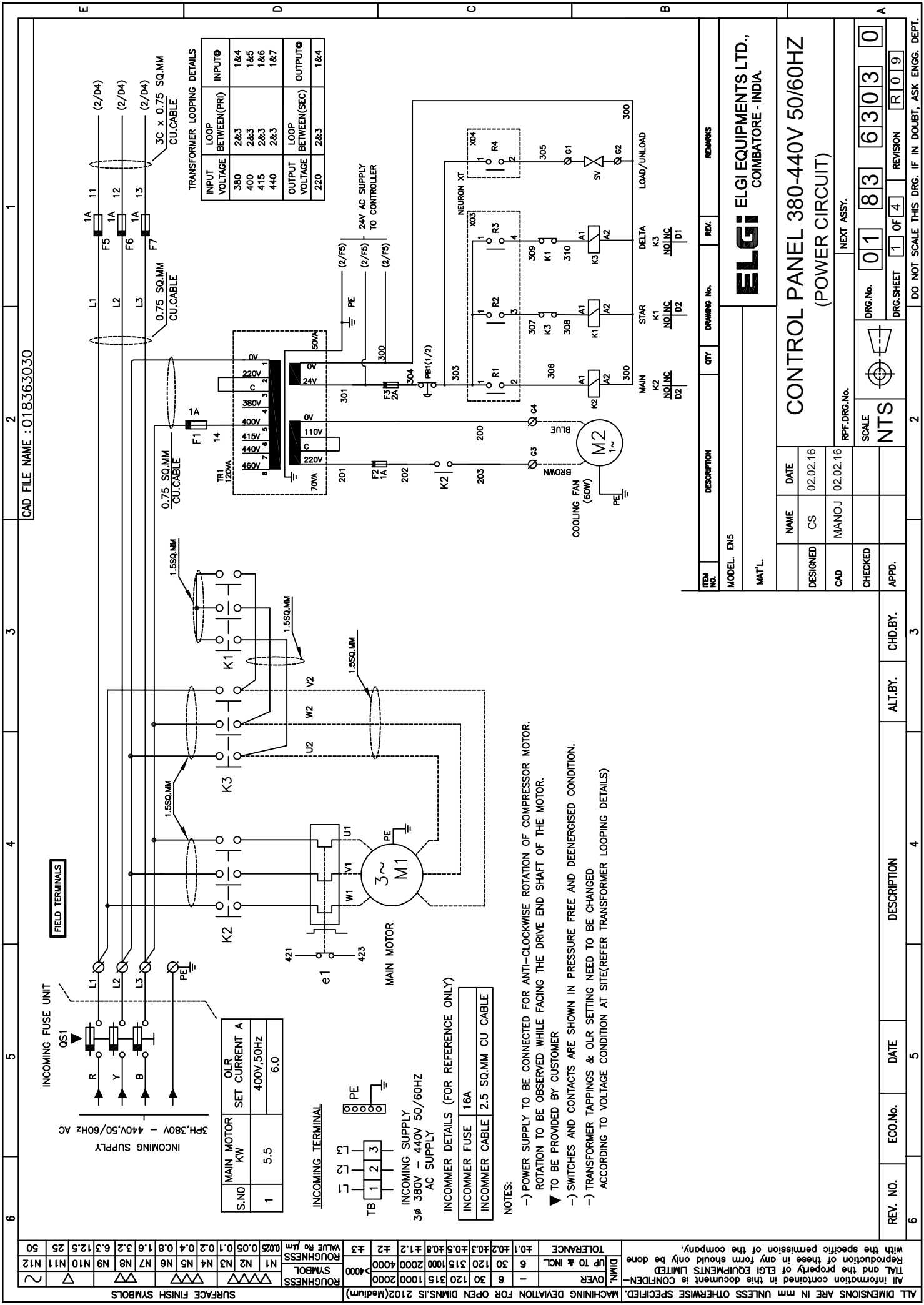

CAD FILE NAME : 018363030

ITEM NO.	DESCRIPTION	QTY	DRAWING No.	REV.	REMARKS
	MODEL: ENS				
	MAT'L				

NAME	DATE
DESIGNED CS	02.02.16
CAD MANOJ	02.02.16
CHECKED	
APPD.	

DRG.No.	REV	REVISION
01836303	0	

SCALE	NTS
1 OF 4	

DRG.No.	REV	REVISION
01836303	0	

REV. NO.	ECO.No.	DATE	DESCRIPTION	CHD.BY.	ALT.BY.
6		5			

## CONTROL PANEL 380-440V 50/60HZ (POWER CIRCUIT)

**ELGI** ELGI EQUIPMENTS LTD.,  
COIMBATORE - INDIA.

- NOTES:**
- ) POWER SUPPLY TO BE CONNECTED FOR ANTI-CLOCKWISE ROTATION OF COMPRESSOR MOTOR. ROTATION TO BE OBSERVED WHILE FACING THE DRIVE END SHAFT OF THE MOTOR.
  - ▼ TO BE PROVIDED BY CUSTOMER
  - ) SWITCHES AND CONTACTS ARE SHOWN IN PRESSURE FREE AND DEENERGISED CONDITION.
  - ) TRANSFORMER TAPPINGS & OLR SETTING NEED TO BE CHANGED ACCORDING TO VOLTAGE CONDITION AT SITE (REFER TRANSFORMER LOOPING DETAILS)

S.NO	MAIN MOTOR KW	OLR SET CURRENT A
1	5.5	6.0

INCOMING SUPPLY  
3Ø 380V - 440V 50/60HZ  
AC SUPPLY

INCOMMER DETAILS (FOR REFERENCE ONLY)	
INCOMMER FUSE	16A
INCOMMER CABLE	2.5 SQ.MM CU CABLE

ROUGHNESS	SYMBOL	VALUE Re /fm
N1	▽▽	0.05
N2	▽▽	0.1
N3	▽▽	0.2
N4	▽▽	0.4
N5	▽▽	0.8
N6	▽▽	1.6
N7	▽▽	3.2
N8	▽▽	6.3
N9	▽▽	12.5
N10	▽▽	25
N11	▽▽	50
N12	▽▽	100

DIM.	OVER	UP TO & INCL.	TOLERANCE
1	6	30	±0.1
30	120	40.3	±0.2
120	415	1000	±0.5
415	1000	10000	±1.2
1000	10000	100000	±3

ALL DIMENSIONS ARE IN MM UNLESS OTHERWISE SPECIFIED. MACHINING DEVIATION FOR OPEN DIMS. IS 2102 (Medium) SURFACE FINISH SYMBOLS

All information contained in this document is CONFIDENTIAL and the property of ELGI EQUIPMENTS LIMITED. Reproduction of these in any form should only be done with the specific permission of the company.

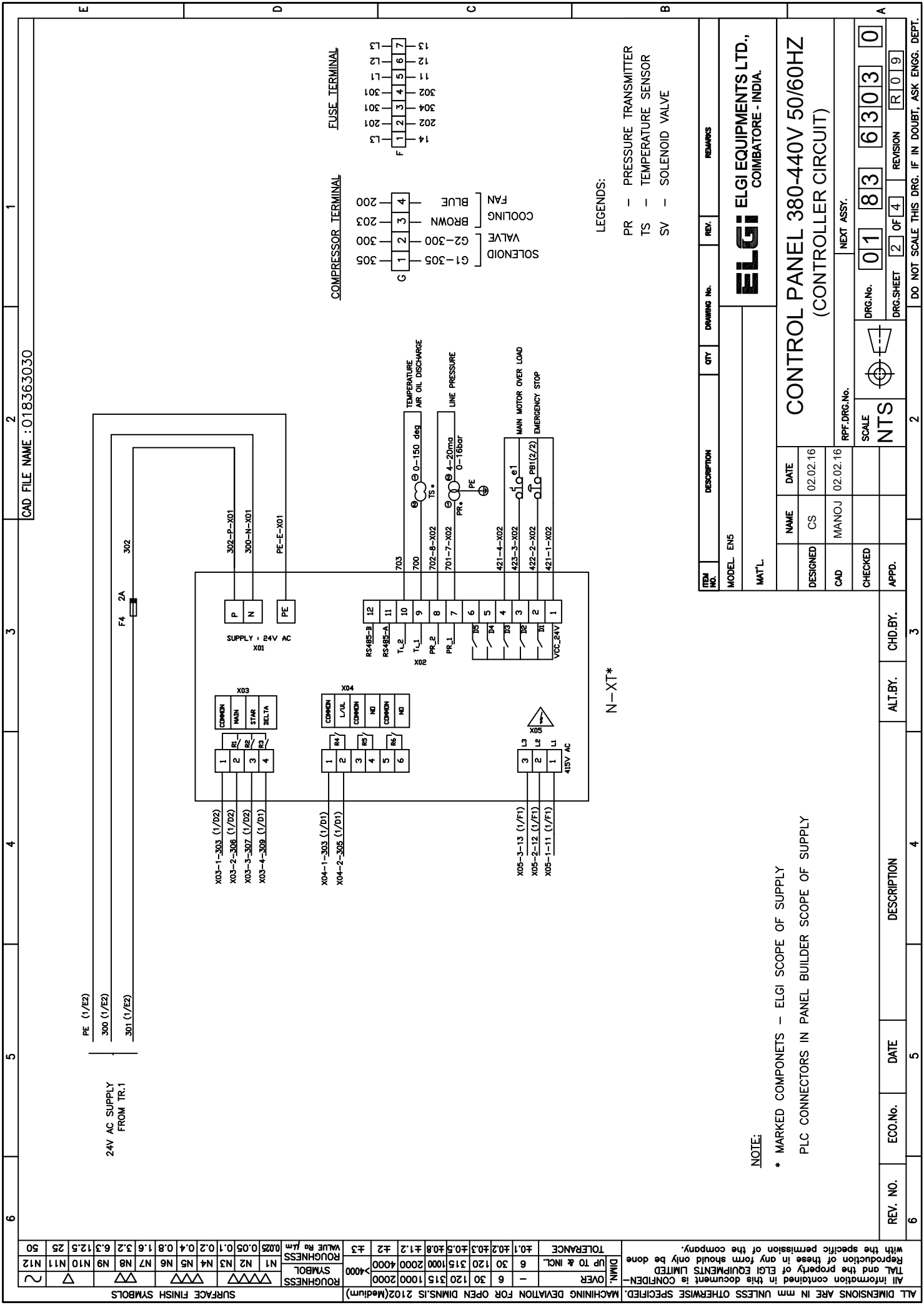

CAD FILE NAME : 018363030

ITEM NO.	DESCRIPTION	CITY	DRAWING No.	REV.	REMARKS
MODEL ENS					
MAT'L					

**ELGI** ELGI EQUIPMENTS LTD.,  
COIMBATORE - INDIA.

**CONTROL PANEL 380-440V 50/60HZ**  
(CONTROLLER CIRCUIT)

SCALE: NTS  
RPF.DRG.No. NEXT ASSY.

DESIGNED	NAME	DATE
CS	MANOJ	02.02.16
CAD	CHECKED	APPD.

REV. NO.	ECO.No.	DATE	DESCRIPTION	ALT.BY.	CHD.BY.
6		5			3
5		5			3
4		5			3
3		5			3
2		5			3
1		5			3

NOTE: \* MARKED COMPONENTS - ELGI SCOPE OF SUPPLY  
PLC CONNECTORS IN PANEL BUILDER SCOPE OF SUPPLY

ALL DIMENSIONS ARE IN mm UNLESS OTHERWISE SPECIFIED. MACHINING DEVIATION FOR OPEN DIMS. IS 2102 (Medium) SURFACE FINISH SYMBOLS

2

DO NOT SCALE THIS DRG. IF IN DOUBT, ASK ENGG. DEPT.

2		3		4		5		6		1																																																																																																																	
CAD FILE NAME : 018363030																																																																																																																											
BILL OF MATERIAL																																																																																																																											
<table border="1"> <thead> <tr> <th>S.NO</th> <th>CODE</th> <th>DESCRIPTION</th> <th>MAKE</th> <th>RATING</th> <th>ELGI PART CODE</th> <th>QTY</th> </tr> </thead> <tbody> <tr> <td>1</td> <td>K2</td> <td>POWER CONTACTOR</td> <td>SIEMENS</td> <td>9A, 3RT2016-1AB01, S00, 24V</td> <td>008900130</td> <td>1</td> </tr> <tr> <td>2</td> <td>K1,K3</td> <td>POWER CONTACTOR</td> <td>SIEMENS</td> <td>9A, 3RT2016-1AB02, S00, 24V</td> <td>008900310</td> <td>2</td> </tr> <tr> <td>3</td> <td>TR1</td> <td>MULTI TAP TRANSFORMER(TOP TERMINALS)</td> <td>PROCON</td> <td>120VA,0-220-C-380-400-415-440-460V/ S1-0-24V(50VA), S2-0-110-C-220V(70VA)</td> <td>008900291</td> <td>1</td> </tr> <tr> <td>4</td> <td>e1</td> <td>OVERLOAD RELAY MAIN MOTOR</td> <td>SIEMENS</td> <td>5.5-8A, 3RU2116-1HB0, S00</td> <td>008900610</td> <td>1</td> </tr> <tr> <td>5</td> <td>L1,L2,L3</td> <td>INCOMMER TERMINALS</td> <td>PHOENIX</td> <td>RSC 6-F E WITH END PLATE</td> <td>00894642F</td> <td>3</td> </tr> <tr> <td>6</td> <td>PB1</td> <td>EMERGENCY STOP WITH DIAL PLATE</td> <td>ESBEE</td> <td>EMNXMH1+EC1C(NC) + HB135000</td> <td>008940027</td> <td>1</td> </tr> <tr> <td>7</td> <td>F1-F4</td> <td>FUSE TERMINALS</td> <td>WAGO</td> <td>281-611</td> <td>018362735</td> <td>4</td> </tr> <tr> <td>8</td> <td>F1,F2</td> <td>FUSE</td> <td>PROTECTRON</td> <td>1A,SLOW BLOW</td> <td>00894641A</td> <td>4</td> </tr> <tr> <td>9</td> <td>F3,F4</td> <td>FUSE</td> <td>PROTECTRON</td> <td>2A,SLOW BLOW</td> <td>00894642A</td> <td>4</td> </tr> <tr> <td>10</td> <td>G</td> <td>CONTROL TERMINALS</td> <td>WAGO</td> <td>281-101</td> <td>018362734</td> <td>4</td> </tr> <tr> <td>11</td> <td>PE</td> <td>EARTH STRIP</td> <td>-</td> <td>COPPER TIN COATED</td> <td>-</td> <td>1</td> </tr> <tr> <td>12</td> <td>CONNECTOR</td> <td>NEURON XT CONNECTOR</td> <td>WAGO</td> <td>PIN : 2,12,4,6,3</td> <td>00897903T</td> <td>EACH1</td> </tr> <tr> <td>13</td> <td>TS</td> <td>TEMPERATURE SENSOR</td> <td>DANFOSS</td> <td>MBT 3270-PT1000</td> <td>018400078</td> <td>1</td> </tr> <tr> <td>14</td> <td>PR</td> <td>PRESSURE TRANSMITTER</td> <td>DANFOSS</td> <td>MBS1900</td> <td>00897902N</td> <td>1</td> </tr> <tr> <td>15</td> <td>N-XT</td> <td>NEURON XT CONTROLLER</td> <td>ELGI</td> <td>-</td> <td>018362887</td> <td>1</td> </tr> </tbody> </table>												S.NO	CODE	DESCRIPTION	MAKE	RATING	ELGI PART CODE	QTY	1	K2	POWER CONTACTOR	SIEMENS	9A, 3RT2016-1AB01, S00, 24V	008900130	1	2	K1,K3	POWER CONTACTOR	SIEMENS	9A, 3RT2016-1AB02, S00, 24V	008900310	2	3	TR1	MULTI TAP TRANSFORMER(TOP TERMINALS)	PROCON	120VA,0-220-C-380-400-415-440-460V/ S1-0-24V(50VA), S2-0-110-C-220V(70VA)	008900291	1	4	e1	OVERLOAD RELAY MAIN MOTOR	SIEMENS	5.5-8A, 3RU2116-1HB0, S00	008900610	1	5	L1,L2,L3	INCOMMER TERMINALS	PHOENIX	RSC 6-F E WITH END PLATE	00894642F	3	6	PB1	EMERGENCY STOP WITH DIAL PLATE	ESBEE	EMNXMH1+EC1C(NC) + HB135000	008940027	1	7	F1-F4	FUSE TERMINALS	WAGO	281-611	018362735	4	8	F1,F2	FUSE	PROTECTRON	1A,SLOW BLOW	00894641A	4	9	F3,F4	FUSE	PROTECTRON	2A,SLOW BLOW	00894642A	4	10	G	CONTROL TERMINALS	WAGO	281-101	018362734	4	11	PE	EARTH STRIP	-	COPPER TIN COATED	-	1	12	CONNECTOR	NEURON XT CONNECTOR	WAGO	PIN : 2,12,4,6,3	00897903T	EACH1	13	TS	TEMPERATURE SENSOR	DANFOSS	MBT 3270-PT1000	018400078	1	14	PR	PRESSURE TRANSMITTER	DANFOSS	MBS1900	00897902N	1	15	N-XT	NEURON XT CONTROLLER	ELGI	-	018362887	1
S.NO	CODE	DESCRIPTION	MAKE	RATING	ELGI PART CODE	QTY																																																																																																																					
1	K2	POWER CONTACTOR	SIEMENS	9A, 3RT2016-1AB01, S00, 24V	008900130	1																																																																																																																					
2	K1,K3	POWER CONTACTOR	SIEMENS	9A, 3RT2016-1AB02, S00, 24V	008900310	2																																																																																																																					
3	TR1	MULTI TAP TRANSFORMER(TOP TERMINALS)	PROCON	120VA,0-220-C-380-400-415-440-460V/ S1-0-24V(50VA), S2-0-110-C-220V(70VA)	008900291	1																																																																																																																					
4	e1	OVERLOAD RELAY MAIN MOTOR	SIEMENS	5.5-8A, 3RU2116-1HB0, S00	008900610	1																																																																																																																					
5	L1,L2,L3	INCOMMER TERMINALS	PHOENIX	RSC 6-F E WITH END PLATE	00894642F	3																																																																																																																					
6	PB1	EMERGENCY STOP WITH DIAL PLATE	ESBEE	EMNXMH1+EC1C(NC) + HB135000	008940027	1																																																																																																																					
7	F1-F4	FUSE TERMINALS	WAGO	281-611	018362735	4																																																																																																																					
8	F1,F2	FUSE	PROTECTRON	1A,SLOW BLOW	00894641A	4																																																																																																																					
9	F3,F4	FUSE	PROTECTRON	2A,SLOW BLOW	00894642A	4																																																																																																																					
10	G	CONTROL TERMINALS	WAGO	281-101	018362734	4																																																																																																																					
11	PE	EARTH STRIP	-	COPPER TIN COATED	-	1																																																																																																																					
12	CONNECTOR	NEURON XT CONNECTOR	WAGO	PIN : 2,12,4,6,3	00897903T	EACH1																																																																																																																					
13	TS	TEMPERATURE SENSOR	DANFOSS	MBT 3270-PT1000	018400078	1																																																																																																																					
14	PR	PRESSURE TRANSMITTER	DANFOSS	MBS1900	00897902N	1																																																																																																																					
15	N-XT	NEURON XT CONTROLLER	ELGI	-	018362887	1																																																																																																																					
<table border="1"> <tr> <td>ITEM NO.</td> <td>DESCRIPTION</td> <td>CITY</td> <td>DRAWING No.</td> <td>REV.</td> <td>REMARKS</td> </tr> <tr> <td>MODEL ENS</td> <td></td> <td></td> <td></td> <td></td> <td></td> </tr> <tr> <td>MAT'L</td> <td></td> <td></td> <td></td> <td></td> <td></td> </tr> <tr> <td>NAME</td> <td>DATE</td> <td></td> <td></td> <td></td> <td></td> </tr> <tr> <td>DESIGNED CS</td> <td>02.02.16</td> <td></td> <td></td> <td></td> <td></td> </tr> <tr> <td>CAD MANOJ</td> <td>02.02.16</td> <td></td> <td></td> <td></td> <td></td> </tr> <tr> <td>CHECKED</td> <td></td> <td></td> <td></td> <td></td> <td></td> </tr> <tr> <td>APPD.</td> <td></td> <td></td> <td></td> <td></td> <td></td> </tr> </table>												ITEM NO.	DESCRIPTION	CITY	DRAWING No.	REV.	REMARKS	MODEL ENS						MAT'L						NAME	DATE					DESIGNED CS	02.02.16					CAD MANOJ	02.02.16					CHECKED						APPD.																																																																					
ITEM NO.	DESCRIPTION	CITY	DRAWING No.	REV.	REMARKS																																																																																																																						
MODEL ENS																																																																																																																											
MAT'L																																																																																																																											
NAME	DATE																																																																																																																										
DESIGNED CS	02.02.16																																																																																																																										
CAD MANOJ	02.02.16																																																																																																																										
CHECKED																																																																																																																											
APPD.																																																																																																																											
<table border="1"> <tr> <td colspan="6" style="text-align: center;"><b>ELGI</b> ELGI EQUIPMENTS LTD., COIMBATORE - INDIA.</td> </tr> <tr> <td colspan="6" style="text-align: center;">CONTROL PANEL 380-440V 50/60HZ (BILL OF MATERIALS)</td> </tr> <tr> <td colspan="6" style="text-align: right;">RPF.DRG.No. NEXT ASSY.</td> </tr> <tr> <td>SCALE</td> <td>NTS</td> <td>DRG.No.</td> <td>01</td> <td>83</td> <td>6303</td> </tr> <tr> <td>DRG.SHEET</td> <td>3</td> <td>OF</td> <td>4</td> <td>REVISION</td> <td>R09</td> </tr> </table>												<b>ELGI</b> ELGI EQUIPMENTS LTD., COIMBATORE - INDIA.						CONTROL PANEL 380-440V 50/60HZ (BILL OF MATERIALS)						RPF.DRG.No. NEXT ASSY.						SCALE	NTS	DRG.No.	01	83	6303	DRG.SHEET	3	OF	4	REVISION	R09																																																																																		
<b>ELGI</b> ELGI EQUIPMENTS LTD., COIMBATORE - INDIA.																																																																																																																											
CONTROL PANEL 380-440V 50/60HZ (BILL OF MATERIALS)																																																																																																																											
RPF.DRG.No. NEXT ASSY.																																																																																																																											
SCALE	NTS	DRG.No.	01	83	6303																																																																																																																						
DRG.SHEET	3	OF	4	REVISION	R09																																																																																																																						
<table border="1"> <tr> <td>REV. NO.</td> <td>ECO.No.</td> <td>DATE</td> <td>DESCRIPTION</td> <td>ALT.BY.</td> <td>CHD.BY.</td> </tr> <tr> <td>6</td> <td></td> <td>5</td> <td></td> <td></td> <td></td> </tr> </table>												REV. NO.	ECO.No.	DATE	DESCRIPTION	ALT.BY.	CHD.BY.	6		5																																																																																																							
REV. NO.	ECO.No.	DATE	DESCRIPTION	ALT.BY.	CHD.BY.																																																																																																																						
6		5																																																																																																																									
<table border="1"> <tr> <td>ALL DIMENSIONS ARE IN mm UNLESS OTHERWISE SPECIFIED.</td> <td colspan="11">MACHINING DEVIATION FOR OPEN DIMS.'S 2102(Medium)</td> </tr> <tr> <td>OVER</td> <td>6</td> <td>30</td> <td>120</td> <td>315</td> <td>1000</td> <td>2000</td> <td>4000</td> <td>&gt;4000</td> <td colspan="3"></td> <td></td> </tr> <tr> <td>UP TO &amp; INCL.</td> <td>6</td> <td>30</td> <td>120</td> <td>315</td> <td>1000</td> <td>2000</td> <td>4000</td> <td>&gt;4000</td> <td colspan="3"></td> <td></td> </tr> <tr> <td>TOLERANCE</td> <td>±0.1</td> <td>±0.2</td> <td>±0.3</td> <td>±0.5</td> <td>±0.8</td> <td>±1.2</td> <td>±2</td> <td>±3</td> <td colspan="3"></td> <td></td> </tr> <tr> <td colspan="12">           All information contained in this document is CONFIDENTIAL and the property of ELGI EQUIPMENTS LIMITED. Reproduction of these in any form should only be done with the specific permission of the company.         </td> </tr> </table>												ALL DIMENSIONS ARE IN mm UNLESS OTHERWISE SPECIFIED.	MACHINING DEVIATION FOR OPEN DIMS.'S 2102(Medium)											OVER	6	30	120	315	1000	2000	4000	>4000					UP TO & INCL.	6	30	120	315	1000	2000	4000	>4000					TOLERANCE	±0.1	±0.2	±0.3	±0.5	±0.8	±1.2	±2	±3					All information contained in this document is CONFIDENTIAL and the property of ELGI EQUIPMENTS LIMITED. Reproduction of these in any form should only be done with the specific permission of the company.																																																												
ALL DIMENSIONS ARE IN mm UNLESS OTHERWISE SPECIFIED.	MACHINING DEVIATION FOR OPEN DIMS.'S 2102(Medium)																																																																																																																										
OVER	6	30	120	315	1000	2000	4000	>4000																																																																																																																			
UP TO & INCL.	6	30	120	315	1000	2000	4000	>4000																																																																																																																			
TOLERANCE	±0.1	±0.2	±0.3	±0.5	±0.8	±1.2	±2	±3																																																																																																																			
All information contained in this document is CONFIDENTIAL and the property of ELGI EQUIPMENTS LIMITED. Reproduction of these in any form should only be done with the specific permission of the company.																																																																																																																											
<table border="1"> <tr> <td>ROUGHNESS SYMBOL</td> <td>ROUGHNESS VALUE Re Rm</td> <td>ROUGHNESS SYMBOL</td> <td>ROUGHNESS VALUE Re Rm</td> </tr> <tr> <td>▽</td> <td>0.2</td> <td>▽</td> <td>0.4</td> </tr> <tr> <td>▽</td> <td>0.5</td> <td>▽</td> <td>0.8</td> </tr> <tr> <td>▽</td> <td>1.6</td> <td>▽</td> <td>3.2</td> </tr> <tr> <td>▽</td> <td>6.3</td> <td>▽</td> <td>12.5</td> </tr> <tr> <td>▽</td> <td>25</td> <td>▽</td> <td>50</td> </tr> </table>												ROUGHNESS SYMBOL	ROUGHNESS VALUE Re Rm	ROUGHNESS SYMBOL	ROUGHNESS VALUE Re Rm	▽	0.2	▽	0.4	▽	0.5	▽	0.8	▽	1.6	▽	3.2	▽	6.3	▽	12.5	▽	25	▽	50																																																																																								
ROUGHNESS SYMBOL	ROUGHNESS VALUE Re Rm	ROUGHNESS SYMBOL	ROUGHNESS VALUE Re Rm																																																																																																																								
▽	0.2	▽	0.4																																																																																																																								
▽	0.5	▽	0.8																																																																																																																								
▽	1.6	▽	3.2																																																																																																																								
▽	6.3	▽	12.5																																																																																																																								
▽	25	▽	50																																																																																																																								
SURFACE FINISH SYMBOLS																																																																																																																											

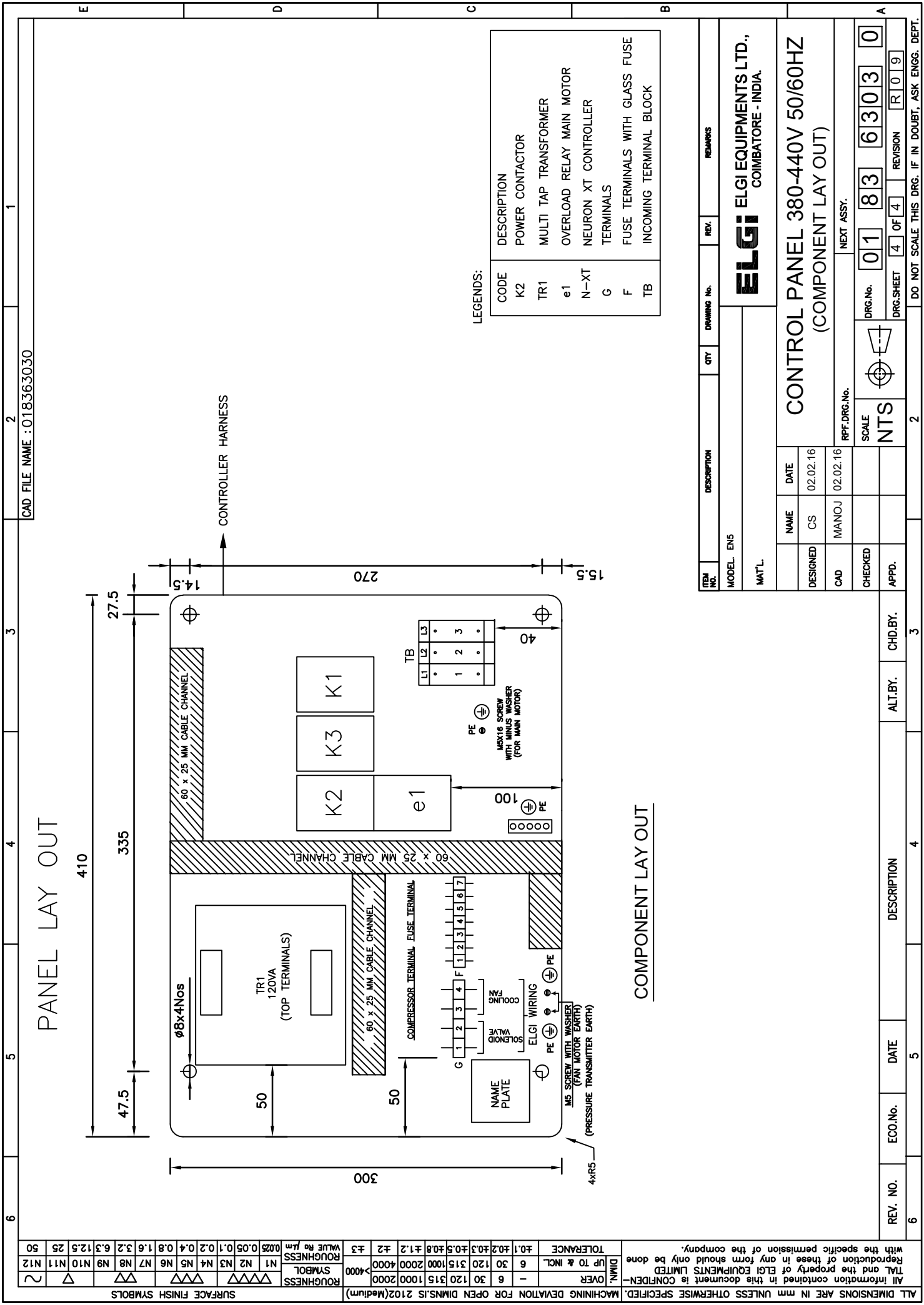

ITEM NO.	DESCRIPTION	CITY	DRAWING No.	REV.	REMARKS
1	MODEL ENS				
2	MAT'L				

REV. NO.	ECO.No.	DATE	DESCRIPTION	ALT.BY.	CHD.BY.
1					
2					

DRWN.	DIM.	TOLERANCE	UP TO & INCL.	OVER	ROUGHNESS	SYMBOL	ROUGHNESS	VALUE Re /mm
6	30	±0.1	6	30	>4000	▽▽▽	N1	0.025
5	120	±0.2	120	315	1000	▽▽	N2	0.05
4	315	±0.3	315	1000	2000	▽	N3	0.1
3	1000	±0.4	1000	2000	4000	▽	N4	0.2
2	2000	±0.5	2000	4000		▽	N5	0.4
1	4000	±0.8	4000			▽	N6	0.8
		±1.2				▽	N7	1.6
		±1.5				▽	N8	3.2
		±2.0				▽	N9	6.3
		±2.5				▽	N10	12.5
		±3.0				▽	N11	25
		±4.0				▽	N12	50

DRG.No.	REV.	SCALE	RPF.DRG.No.	NEXT ASSY.
01	83	NTS		
01	83	NTS		

NAME	DATE
CS	02.02.16
MANOJ	02.02.16

CONTROL PANEL 380-440V 50/60HZ
(COMPONENT LAY OUT)

ELGI	ELGI EQUIPMENTS LTD.,	COIMBATORE - INDIA.
------	-----------------------	---------------------

CODE	DESCRIPTION
K2	POWER CONTACTOR
TR1	MULTI TAP TRANSFORMER
e1	OVERLOAD RELAY MAIN MOTOR
N-XT	NEURON XT CONTROLLER TERMINALS
G	FUSE TERMINALS WITH GLASS FUSE
F	INCOMING TERMINAL BLOCK
TB	

DRG.No.	REV.	SCALE	RPF.DRG.No.	NEXT ASSY.
01	83	NTS		
01	83	NTS		

REV. NO.	ECO.No.	DATE	DESCRIPTION	ALT.BY.	CHD.BY.
1					
2					

CAD FILE NAME : 018363030

DO NOT SCALE THIS DRG. IF IN DOUBT, ASK ENGG. DEPT.

## Branch offices

AHMEDABAD	"ELGI HOUSE" 2, Mill Officer's Colony, Behind La-Gajjar Chambers, (Old Reserve Bank), Opp. Times of India, Ashram Road, Ahmedabad - 380 009, Tel: +961-79- 26583736, 26581274, 26587683, Fax: 91-79-6587683, E-mail: enquiry@elgi.com
BANGALORE	15,16 Richmond Road, Bangalore - 560 025, Tel: +91-80-22537208, Fax: 91-080-22293274, E-mail: enquiry@elgi.com
CHENNAI	S4-II Floor, Apollo Dubai Plaza, No-100, Mahalingapuram Main Road, Nungambakkam, Chennai - 600 034, Tel: +91-44-28172599, 28179500, Fax: 91-44-28174699, E-mail: enquiry@elgi.com
COIMBATORE	1st Floor, No.622-A, Near ELGI industrial Complex, Trichy Road, Singanallur, Coimbatore - 641 005, Tel: +91-422-2589555, Fax: 91-422-2573697, E-mail: enquiry@elgi.com
HYDERABAD	H.NO: 12-13-188, II nd Floor, Street No. 2, Taranaka, Hyderabad - 500 017, Tel: +91-40-27000435, 27000437, 27000439, 27000431, Fax: 91-40-27000438, E-mail: enquiry@elgi.com
JAIPUR	602, 6th Floor, Diamond Tower, Purani Chungi, Ajmer Road, Jaipur - 302 021, Tel: +91-141-2970120, 2970121, E-mail: enquiry@elgi.com
KOCHI	1st Floor, Asset Summit Suites, National Highway 47, Near SCMS, Kalamassery, Kochi - 683106. Tel: +91-484 -2360155, 2351904, E-mail: enquiry@elgi.com
KOLKATA	Space No. 502, Block - C, 5th Floor, Axis Mall, Action Area - 1C, New Town, Premises No. CF - 9, Kolkata - 700 156, Tel: +91-33-2324-4270, 2324-4271, Fax: 91-33-2324-4272, E-mail: enquiry@elgi.com
MUMBAI	Marol Co-op Industrial Estate Ltd. Plot No.48, Mathurdas Vassanji Road, Near Sakinaka, Andheri (East), Mumbai-400 059, Tel: +91-22-42161000, Fax: 91-22-28591601, E-mail: enquiry@elgi.com
NEW DELHI	23, Shivaji Marg, Near Karampura, Opp.DCM, New Delhi - 110 015, Tel: +91-11-25928095, 25153644, 25175018, Fax: 91-11-25459375, E-mail: enquiry@elgi.com
PUNE	White House, Ground Floor, 388/A-1/2240, Mumbai - Pune Road, Opp. Sandvik(Asia), Dapodi, Pune - 411 012, Tel: +91- 20-30635457, Fax: 91-20-4073759, E-mail: enquiry@elgi.com
RAIPUR	Om1, 1st Floor, Ashoka Millennium, Ring Road No.1, Raipur - 492 003, Chhattisgarh, Tel: +91-97520 93008, Fax: 91-771-4073759, E-mail: enquiry@elgi.com
TIRUCHENGODE	4/2, Nandhini Complex, 1st Floor, Velur Road, Tiruchengode - 637 211, Tel: +91-4288-257137, Fax: 91-4288-257693, E-mail: enquiry@elgi.com

## Overseas offices

MALAYSIA	ELGI EQUIPMENTS LIMITED, No.7, Jalan Anggerik Mokara 31/44, Sek. 31, kota kemuning, 40460 Shah Alam, Selangor, Malaysia, Tel: +603-5120-1544 Web: www.elgi.com.my
THAILAND	ELGI EQUIPMENTS LIMITED, 223/66, 14th Floor, Building A, Country Complex, Sanphawut Road, Bang Na, Bangkok, Thailand - 10260, Tel: +6627455160, Local Use: 02-7455160, E-mail: thailand-enquiry@elgi.com, Web: www.elgi.co.th

## Overseas fellow subsidiaries

AUSTRALIA	ELGI EQUIPMENTS PTY LTD., Unit 1, 33 Kingsbury Street, Brendale Queensland - 4500. Australia, Tel: +61 7 3106 0589, Fax: +61-7 3106 0537, Email: enquiry@elgi.com.au, Web: www.elgi.com.au
BRAZIL	ELGI COMPRESSORES DO BRASIL LTD, Av. Emílio Chechinatto, 4195 - Bairro São Roque da Chave, CEP:13.295-000, Itupeva - São PauloBrasil, Tel: +55-11-4496 5519, 4496 6611, E-mail: enquiry@elgi.com.br
CHINA	ELGI EQUIPMENTS (ZHEJIANG) LIMITED, West of 1st Floor, Building 2, No. 232, Yunhai Road, Jiaxing 314033 P.R. China, Tel: +86-573-82079100, Hotline: 400-826-3585 E-mail: enquiry.cn@elgi.com, Web: elgi.cn ELGI COMPRESSORS TRADING (SHANGHAI) CO.,LTD. Rm 912-913, No. 8-9, Lane 1500, South Lianhua Road, Shanghai 201108 P.R. China, Tel: +86-21-33581191, Hotline: 400-826-3585, E-mail: enquiry.cn@elgi.com, Web: elgi.cn
INDONESIA	PT ELGI EQUIPMENTS INDONESIA, Kawasan Pergudangan, Bizpark Commercial Estate, Pulogadung Jl, Raya Bekasi Km. 21, 5 Block A3 No. 12, Kel. Rawa Terate, Kec. Cakung, Pulogadung Jakarta Timur 13920, Tel: +62-21- 46822216, 46827388, E mail: indonesia-enquiry@elgi.com, Web: www.elgi.co.id
ITALY	ROTAIR Spa, Via Bernezzo-67, 12023, Caraglio (CN), Italy, Tel: +39 0171619676, Fax: +39-0171619677, E-mail: info@rotairspa.com, Web: www.rotairspa.com
MIDDLE EAST	ELGI GULF FZE, PO Box: 120695, P6-27, SAIF Zone, Sharjah, U.A.E. Tel: +971 6 557 9970, +971 50 457 6470, Fax: +971 6 557 9980, E-mail: gulfenquiry@elgi.com, Web: www.elgigulf.com
USA	ELGI COMPRESSORS USA, INC. 1500 Suite N Continental Blvd, Charlotte, NC 28273, USA. Tel: +1-704-943-7966, E-mail: usa.sales@elgi.com



## **FACTORY & REGISTERED OFFICE**

### **ELGI EQUIPMENTS LIMITED**

Singanallur, Coimbatore - 641 005,  
India (CIN:L29120TZ1960PLC000351).  
Tel: +91-422-2589555  
Fax: +91-422-2573697, +91-422-2589401  
E-mail: communications@elgi.com, Web: www.elgi.com

### **ELGI EQUIPMENTS LIMITED (FOUNDRY DIVISION)**

SF No: 212/1A, 213/1, KodangipalayamVillage,  
Nallatipalayam Road, Singarampalayam Post, Kinathukkadavu,  
Kinathukkadavu Taluk,  
Coimbatore - 642 109, India.  
Tel : +91-422-2587631, 620

### **GLOBAL SUPPORT CENTRE**

SF NO 221, 221/2 & 221/3, Kothavadi Road,  
Kodangipalayam Village, Singarampalayam(PO),  
Kinathukkadavu Taluk,  
Coimbatore - 642 109, India.  
Tel : +91-422-2587000.

### **ELGI EQUIPMENTS LIMITED (AIR COMPRESSOR PLANT)**

SF NO 221/1 to 3 - 229/B1, B2, B3, 232/B1,B2, 234/B1, 264/B1 and 264/B2.  
KothavadiRoad, Kodangipalayam Village,  
Singarampalayam (PO) Kinathukkadavu  
Taluk, Coimbatore - 642 109, India.  
Tel : +91-422-2587000.

## **FELLOW SUBSIDIARIES (DOMESTIC)**

### **ATS ELGI LIMITED,**

Kurichy Private Industrial Estate, Kurichy,  
Coimbatore - 641 021, India,  
Tel: +91-422-2589999, 2672201-3,  
Fax: +91-422-2675446,  
E-mail: enquiry@ats-elgi.com,  
Web: www.ats-elgi.com

### **ADISONS PRECISION INSTRUMENTS MFG.CO.LIMITED**

Elgi Industrial Complex, Singanallur,  
Coimbatore - 641 005  
Tel: +91-422-2589555

### **ERGO DESIGN PVT LTD,**

150, 2nd Main, 2nd Cross, Chelekare, Kalyan Nagar,  
Bengaluru, Karnataka 560043,  
Tel: +91-80-42436000

## **JOINT VENTURE**

### **ELGI SAUER COMPRESSORS LIMITED,**

Elgi Industrial Complex III, Singanallur,  
Coimbatore - 641 005, India,  
Tel: +91-422-2589555, 2589634, 2589510,  
Fax: +91-422-2573697,  
E-mail: info@elgisauer.com, Web: www.elgisauer.com

### **INDUSTRIAL AIR SOLUTIONS LLP,**

1, R R Industrial Estate, Opposite Shanthi Gears Regd Office, Singanallur,  
Coimbatore, Tamil Nadu 641005,  
Tel: 0422 227 1862.

## **DIVISION**

### **PRESSURE VESSEL DIVISION**

1473 - Trichy Road, Coimbatore - 641 018,  
Tel: +91-422-2589777,  
Email: enquiry@elgi.com.

---



